

Spread Spectrum Channel Sounder Implementation with USRP Platforms

Adrien LE NAOUR, Olivier GOUBET,
Christophe MOY, Pierre LERAY

SUPELEC

1 December 2011

SUPELEC - Campus de Rennes

SCEE – Signal, Communications et Electronique Embarquée

IETR – UMR CNRS 6164

Institut d'Electronique et Télécommunications de Rennes

- **Past experience on channel sounding**
- **Student project on channel sounding**
- **USRP 1 experiments**
- **N210 experiments**
- **Conclusion**

- **Past experience on channel sounding**
- Student project on channel sounding
- USRP 1 experiments
- N210 experiments
- Conclusion

- Implement a troposcatter channel sounder on a 200 km link @ 4.47 GHz

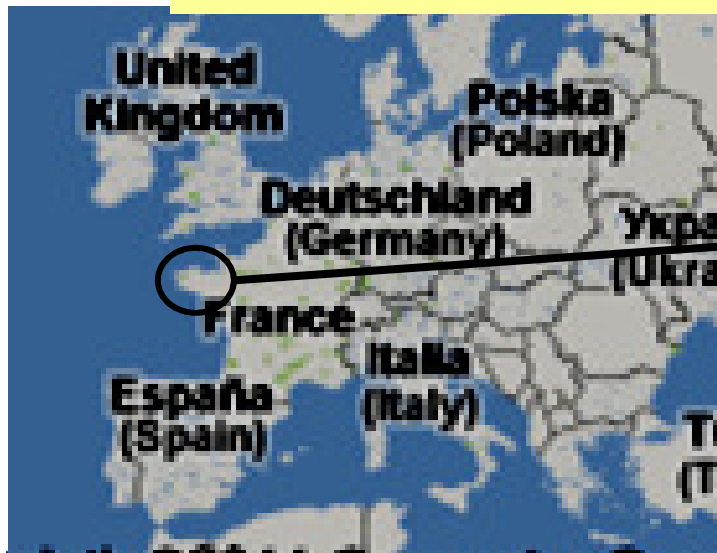
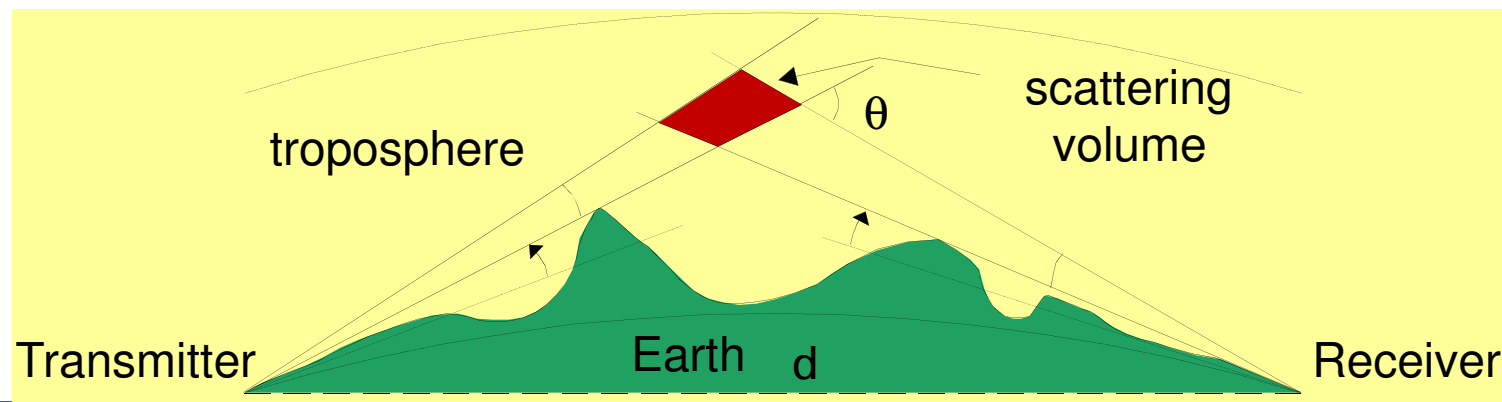

- RF
- frequency translation
- digital baseband

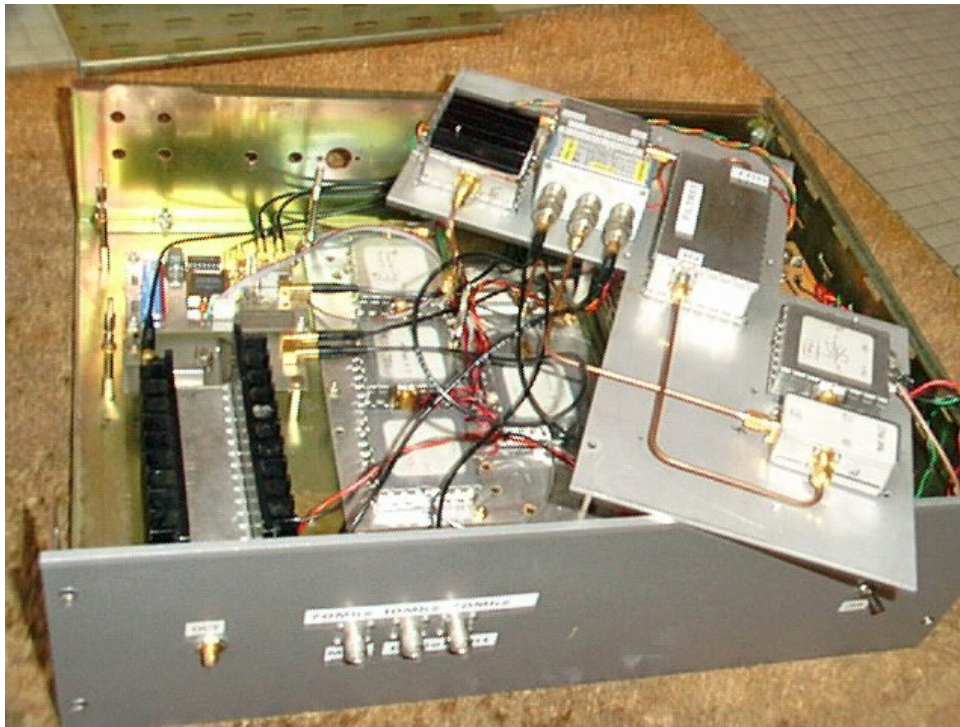

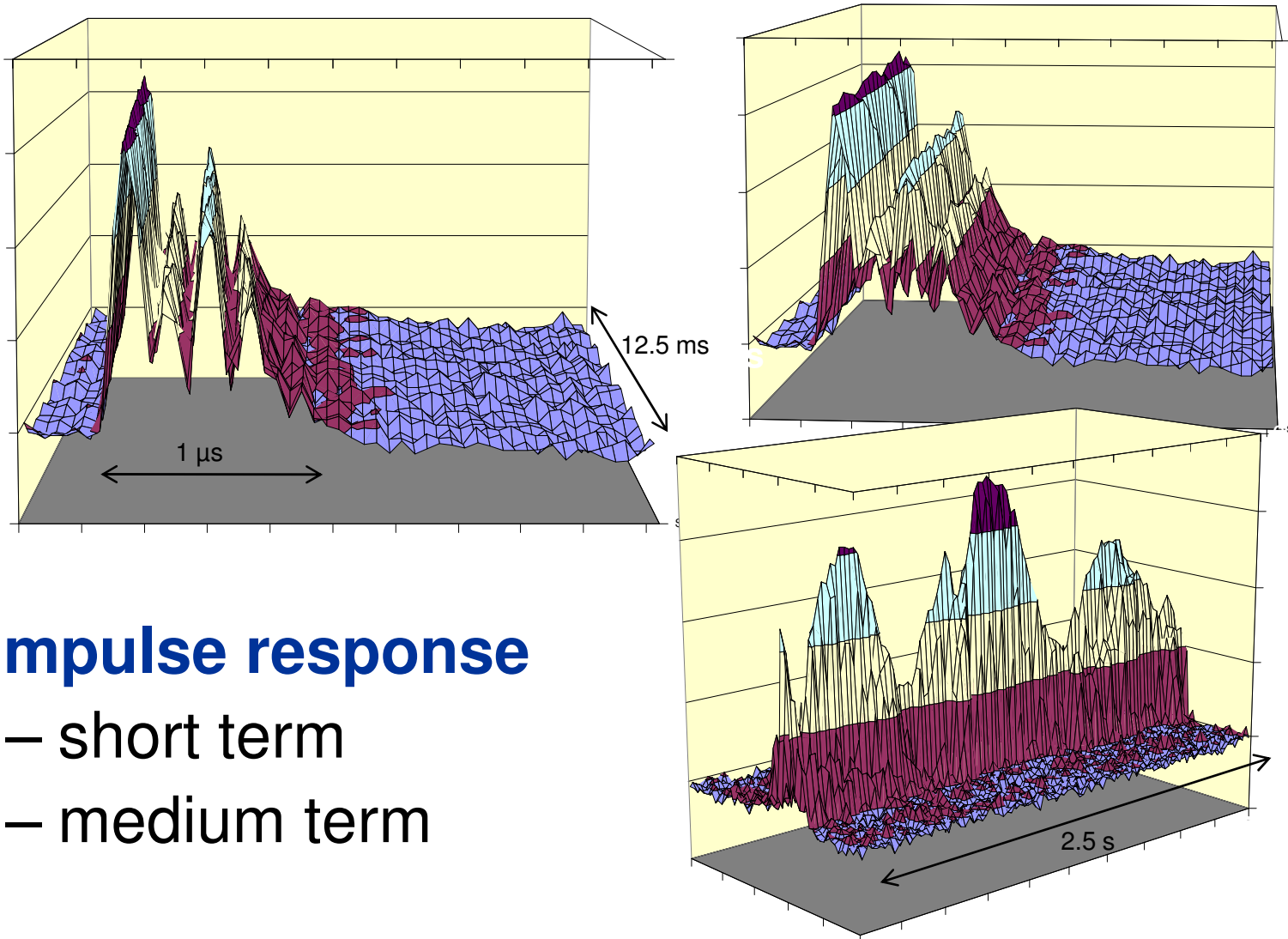

- **Impulse response**
 - short term
 - medium term

- **Direct Sequence Spread Spectrum sounder**

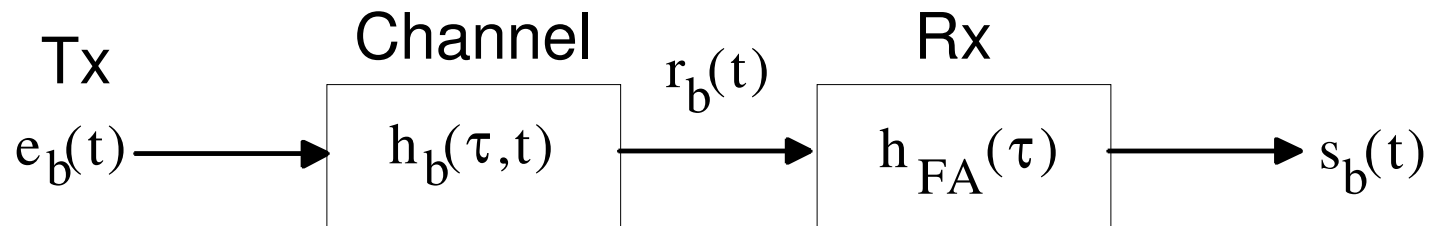

- a m-sequence code is transmitted: $e_b(t) = c(t)$
- matched filter at reception: $h_{FA}(t) = c(\xi - t)$
 - $\xi = L_c \cdot T_c$
 - L_c is the number of chips of a code sequence
 - T_c is the chip length
- $r_b(t) = (c \otimes h_b)(t)$
- $s_b(t) = (c \otimes h_b \otimes h_{FA})(t) = (c \otimes h_{FA} \otimes h_b)(t) = (R_c \otimes h_b)(t)$
- where R_c is the code autocorrelation function

- **Autocorrelation of m-sequence pseudo-random codes**

- example of a 127 chips long code sequence

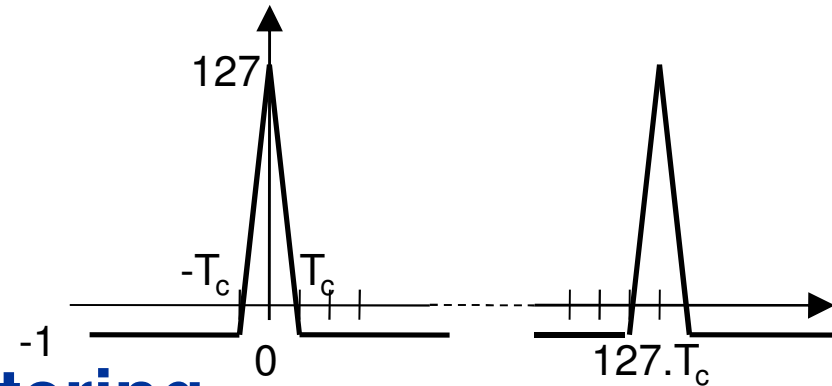

- **Method: matched filtering**

- **Consequence for sounding**

- the larger the signal bandwidth
- the shorter the chip duration
- ➔ the closer to the "real" impulse response
 - thinner peaks
 - lower secondary lobes

- **Direct Sequence Spread Spectrum sounder**

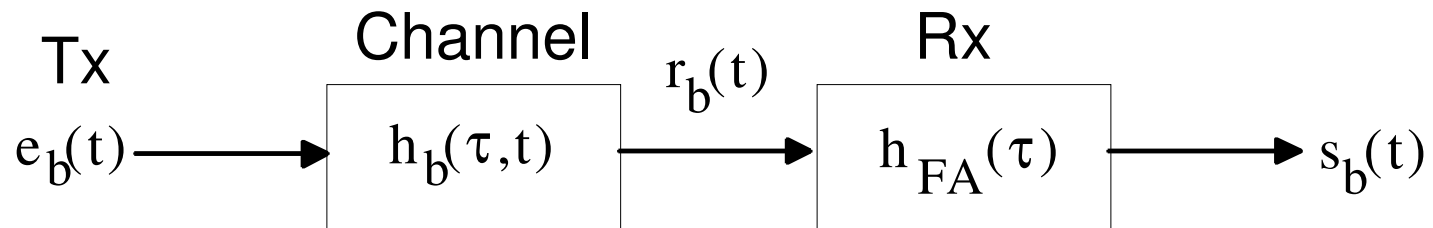

$$- s_b(t) = \sum_{k=0}^{K-1} \alpha_k(t) \cdot e^{-j\theta_k(t)} \cdot R_c(t - \xi - \tau_k) \cdot d\tau$$

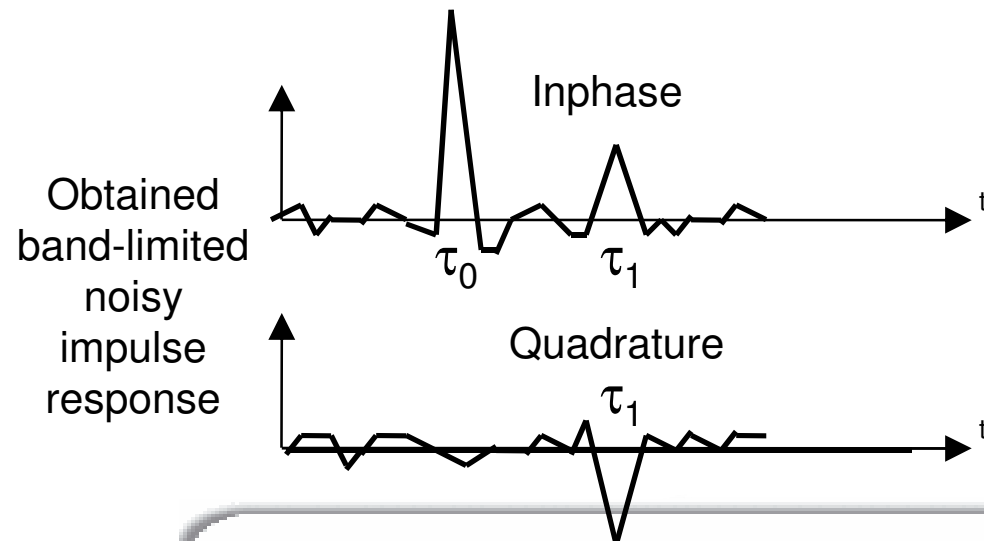
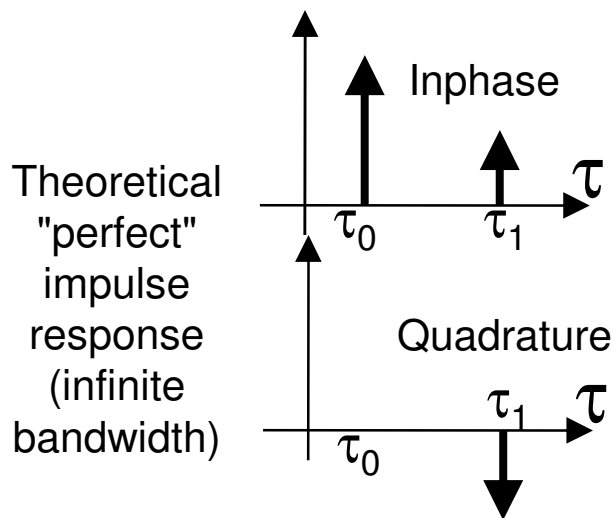

- Past experience on channel sounding
- **Student project on channel sounding**
- USRP 1 experiments
- N210 experiments
- Conclusion

- How to make it now, thanks to SDR facilities?
- Even with undergraduate students
- Only 8 time slots of 4 hours (plus free time) year 1, and the same year 2
- Make students touch implementation difficulties
- Not only a (long and fastidious) theoretical approach as usual when making first steps in radio
- But directly in the reality so that it motivates to study theoretical explanations then

- **First step: understand (year 1)**
- **Design Environment**
 - Ptolemy II
 - Ptolemy project of Berkeley
 - Edward LEE lab
 - multi-domains desing (continuous time, discret time, state machine, SDF, etc.)
 - any application field: automatic, wireless, electronics, etc.
 - <http://ptolemy.berkeley.edu/ptolemyII/>

- **Basic CDMA**

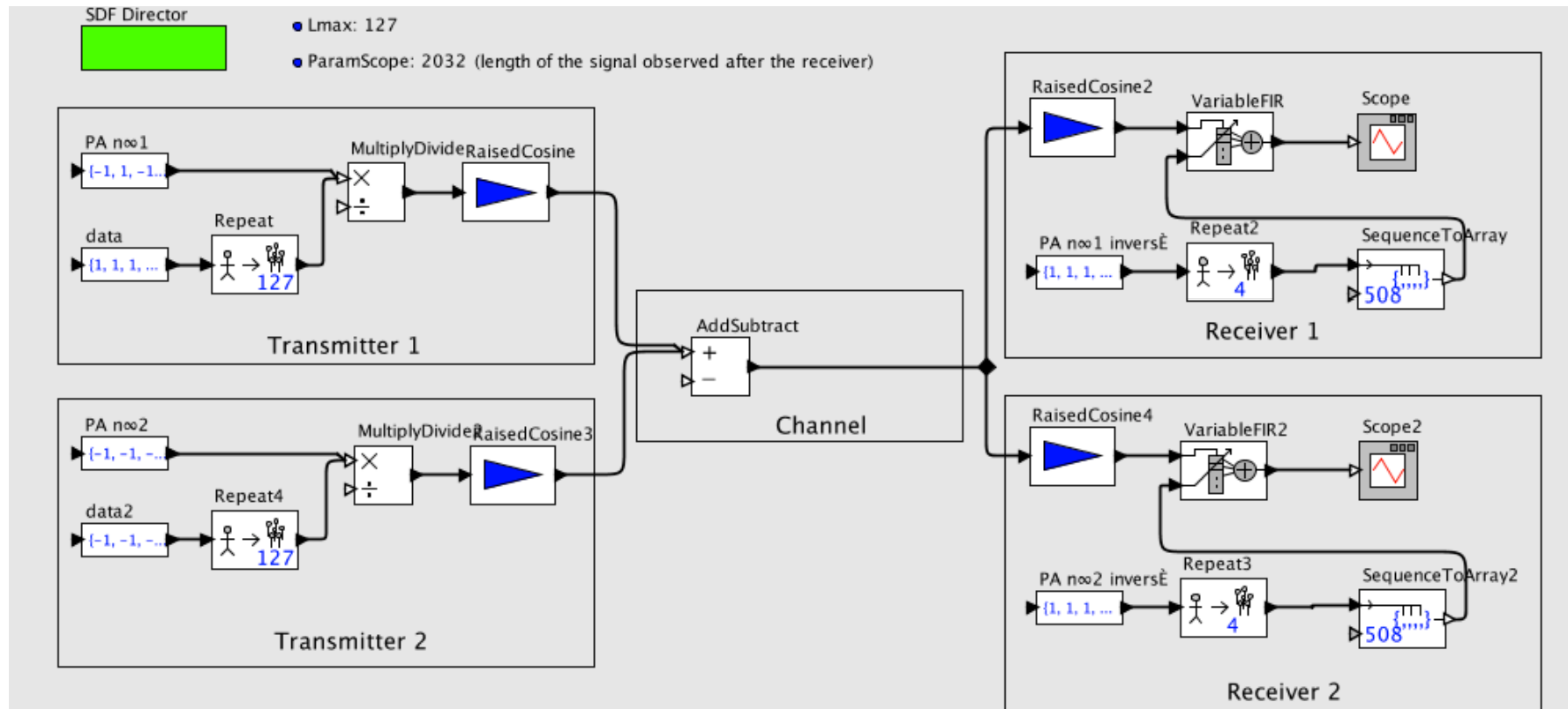

- **Matched filter based at Rx**

- **Insert channel effects**
 - AWGN
 - Multipath

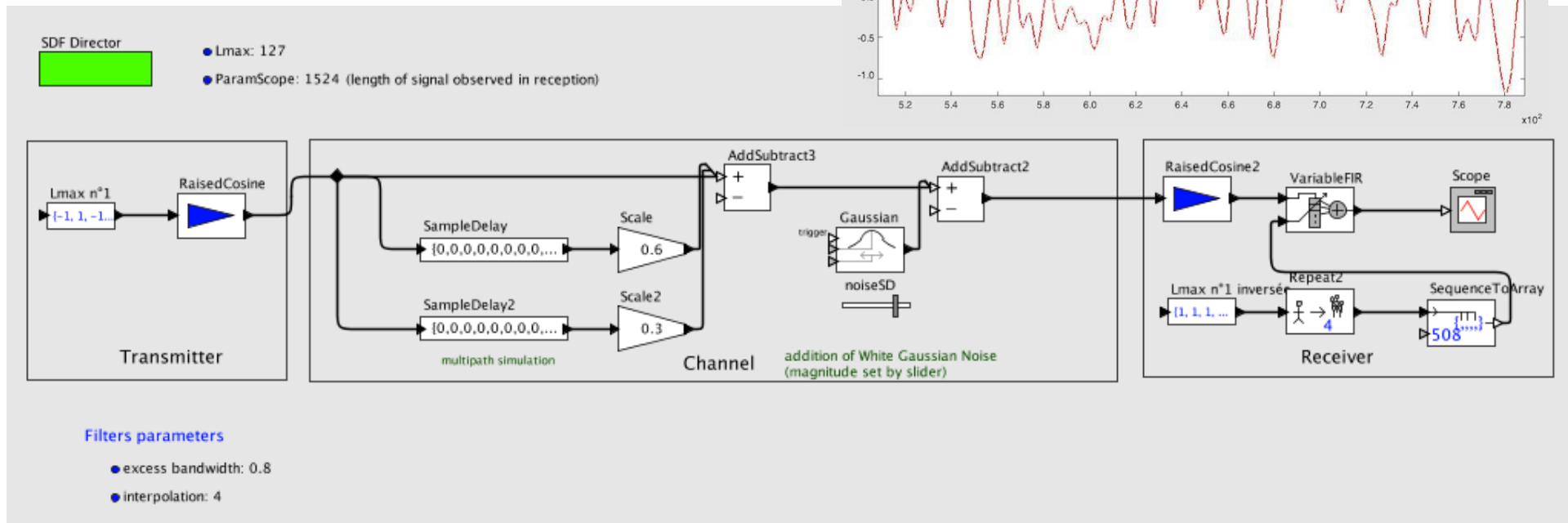
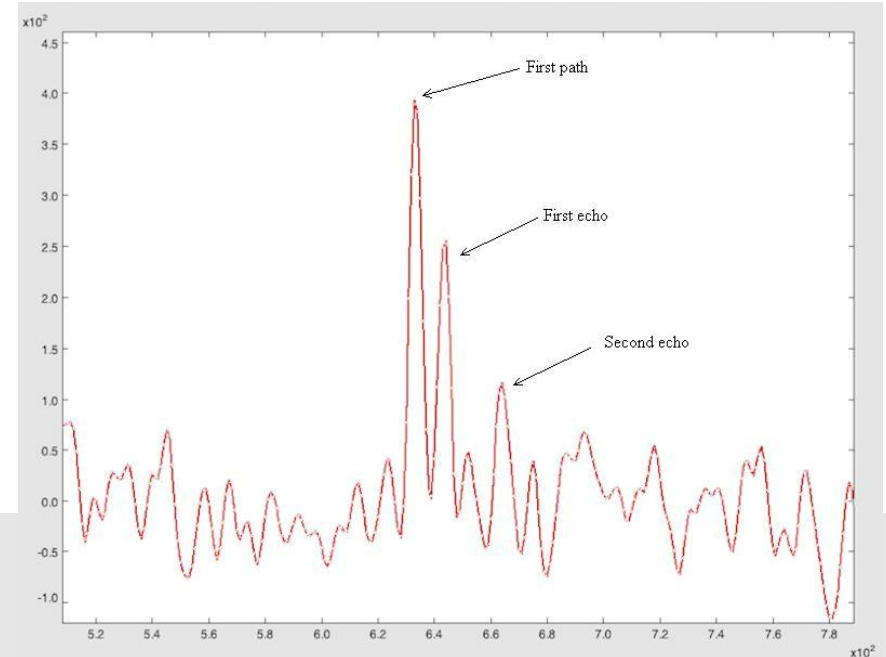

- Past experience on channel sounding
- Student project on channel sounding
- **USRP 1 experiments**
- N210 experiments
- Conclusion

• Tx

• Rx

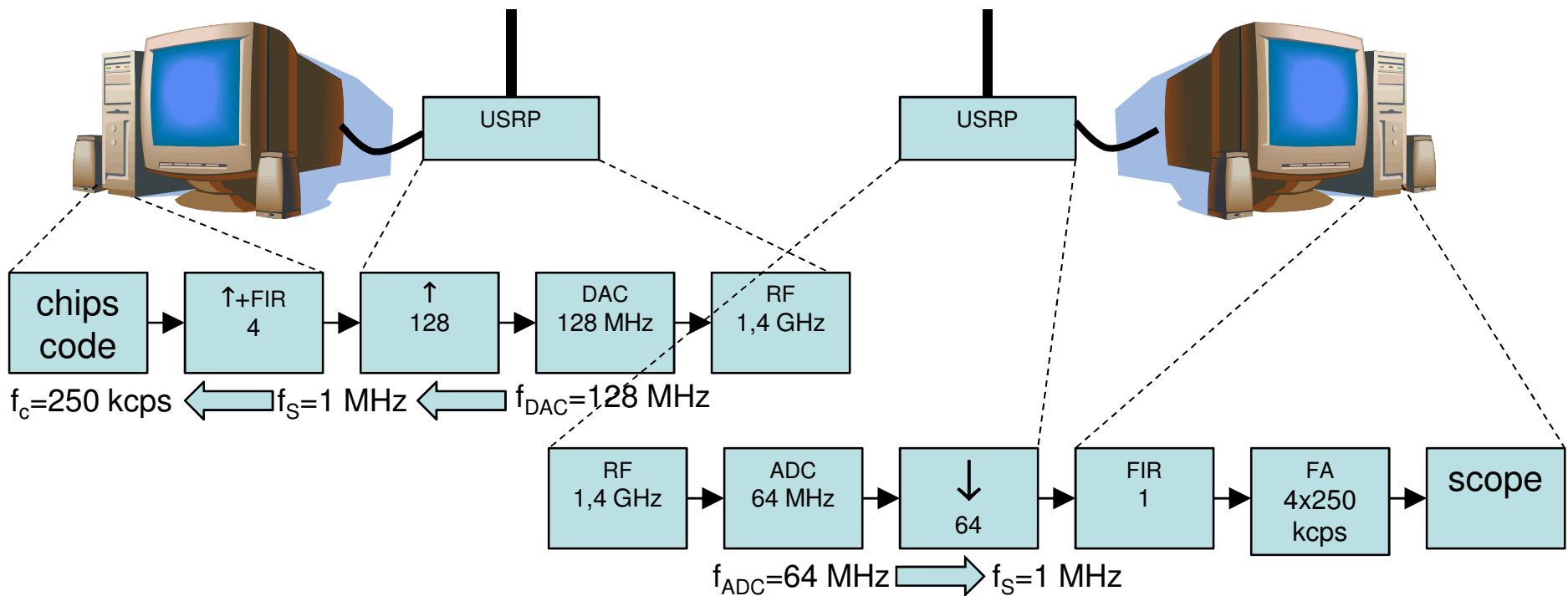

- Tx radio chain**

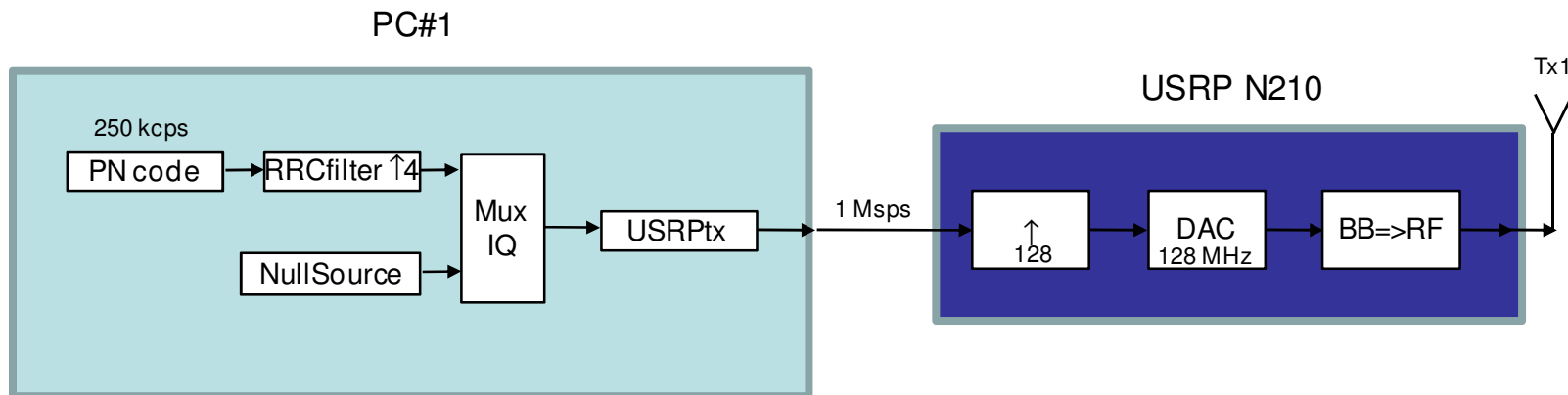

- Rx radio chain**

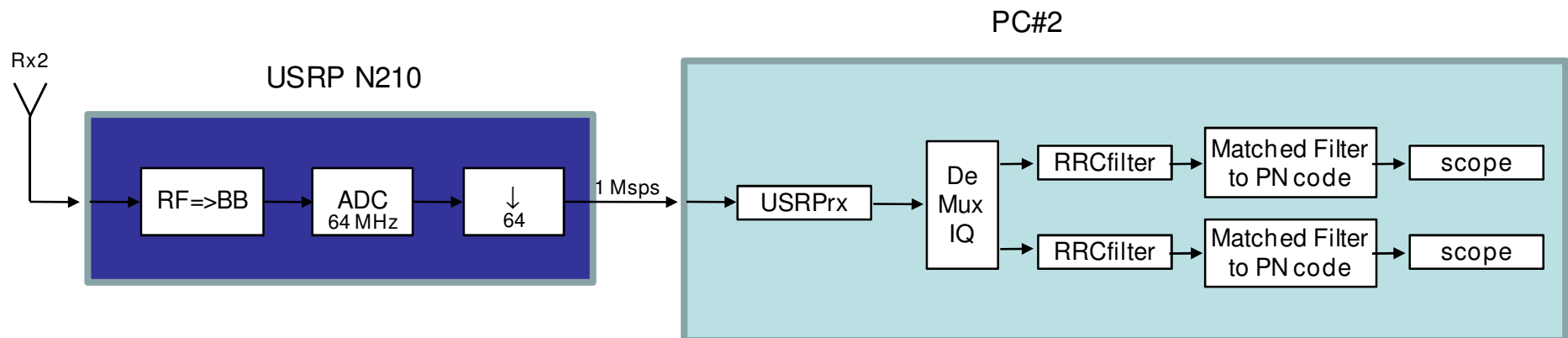

- **Development Environment**
 - GRC (GNU Radio Companion)
- **USB link** (max data transfer rate we obtained: 1 Msps)

- **With an oversampling of 4 in pulse shaping**
 - 250 kHz of bandwidth for sounding
 - path discrimination of 4 μ s

A starting point (enough for getting started in year 2)

- Tx

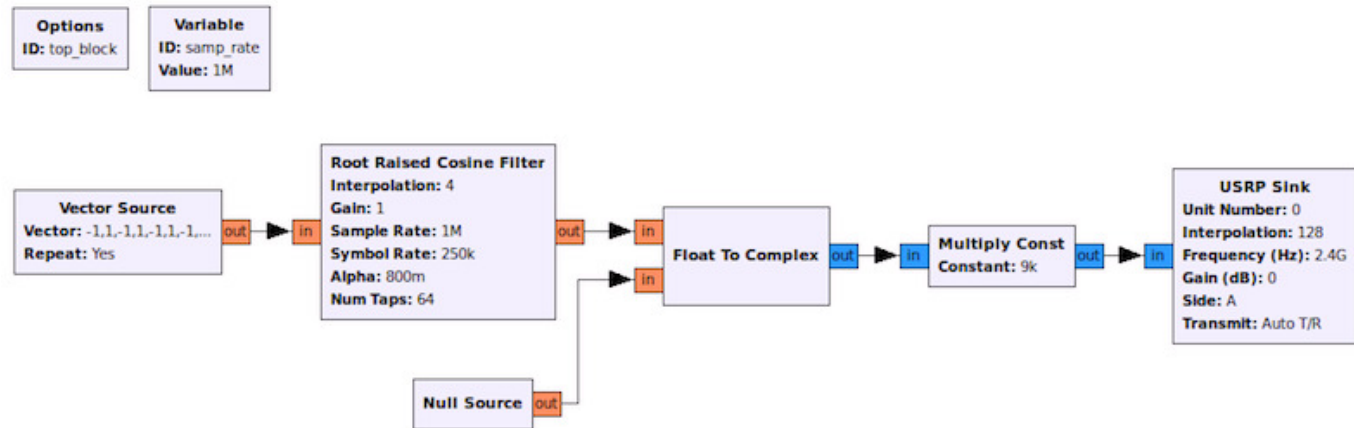

- Rx

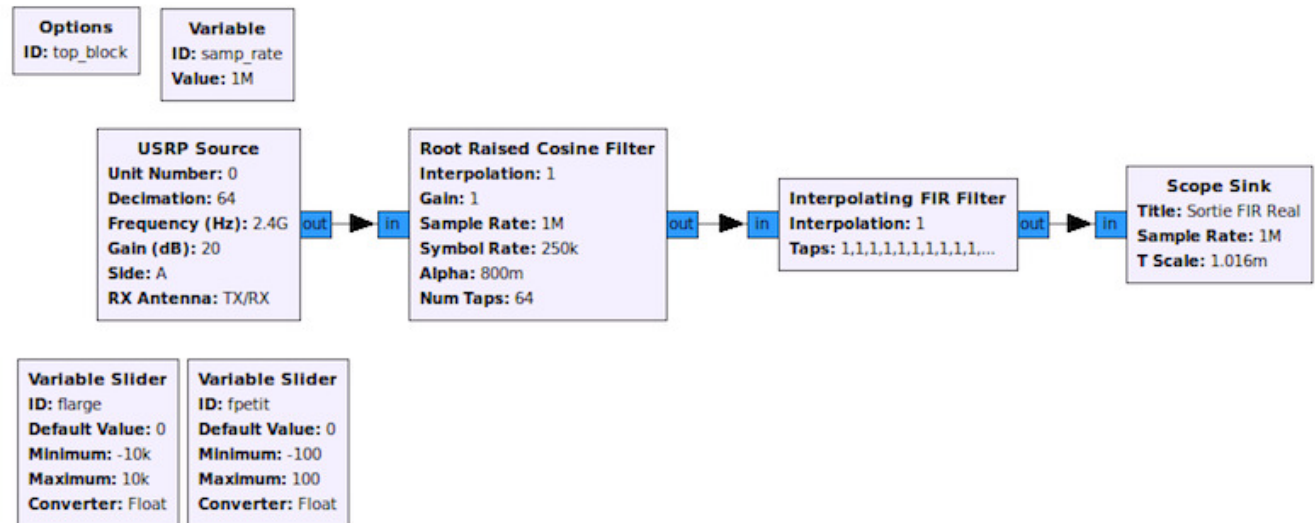

- $W = 250$ kHz
- carrier frequency is 2.4 GHz
- carrier desynchronization

inphase

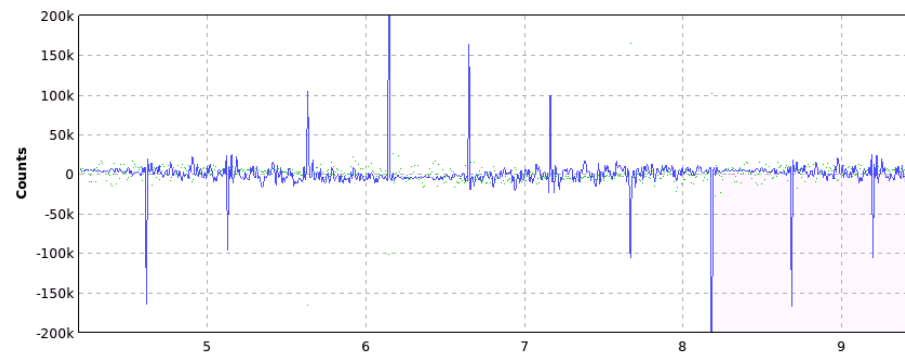

quadrature

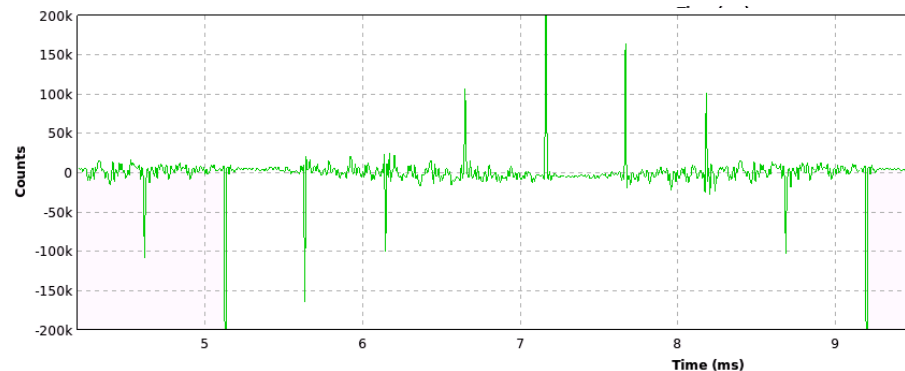

- Transmitted**

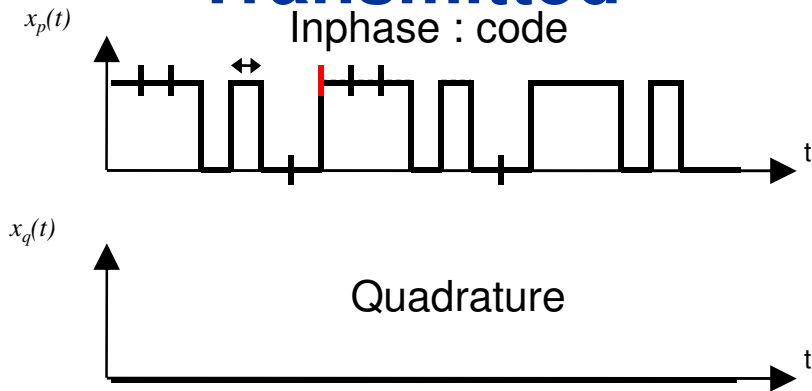

- versus reality**

Received

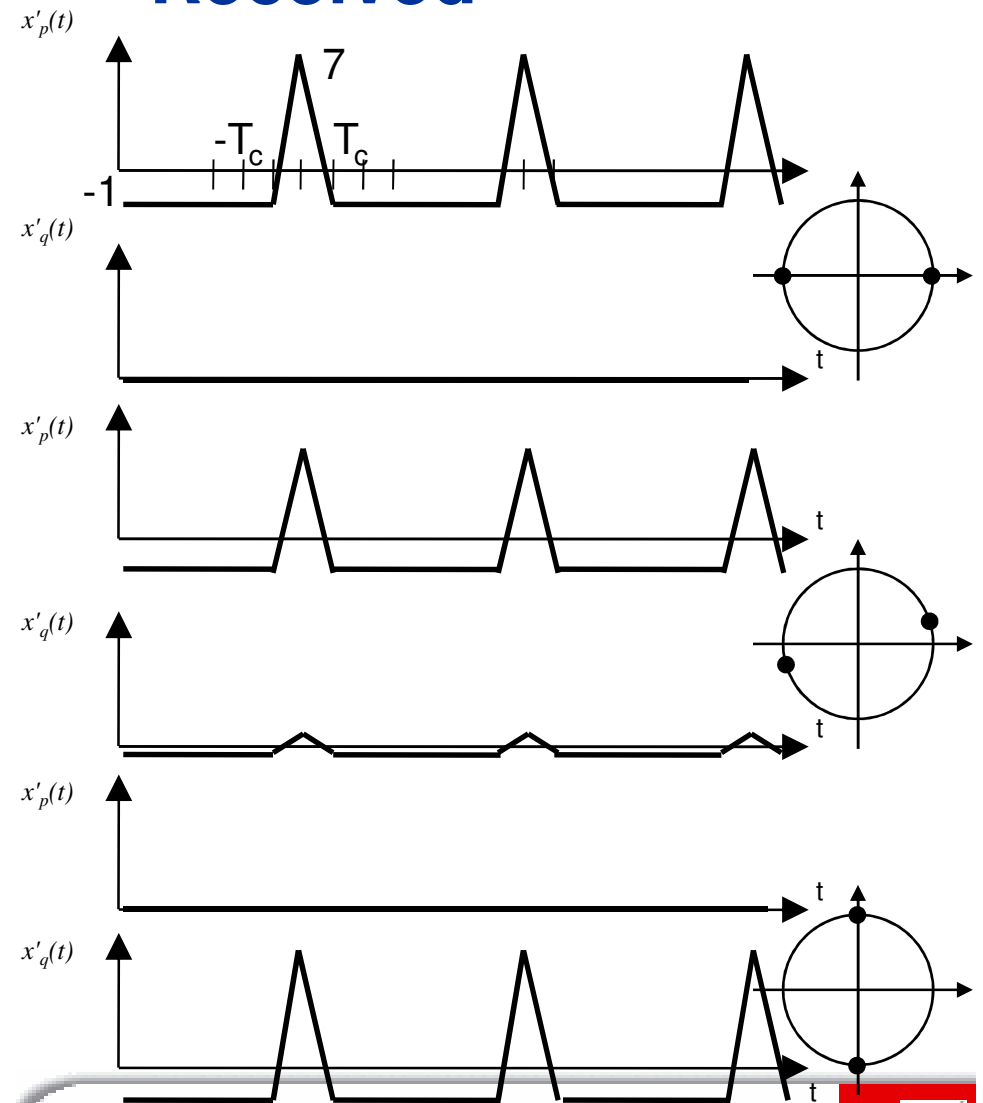

- In a data transmission perspective: how to compensate carrier desynchronization using a channel sounder?
- **UMTS FDD uplink approach:**
 - transmit spread data with code #1 on Inphase
 - transmit a sounding code #2 on Quadrature
 - use "sounding phase" to "re-phase data"
- **Done by students by simulation only as carrier desynchronisation was too high for the implementation constraints**

- Synchronisation proposal for a simulated data transmission
 - continuous phase correction

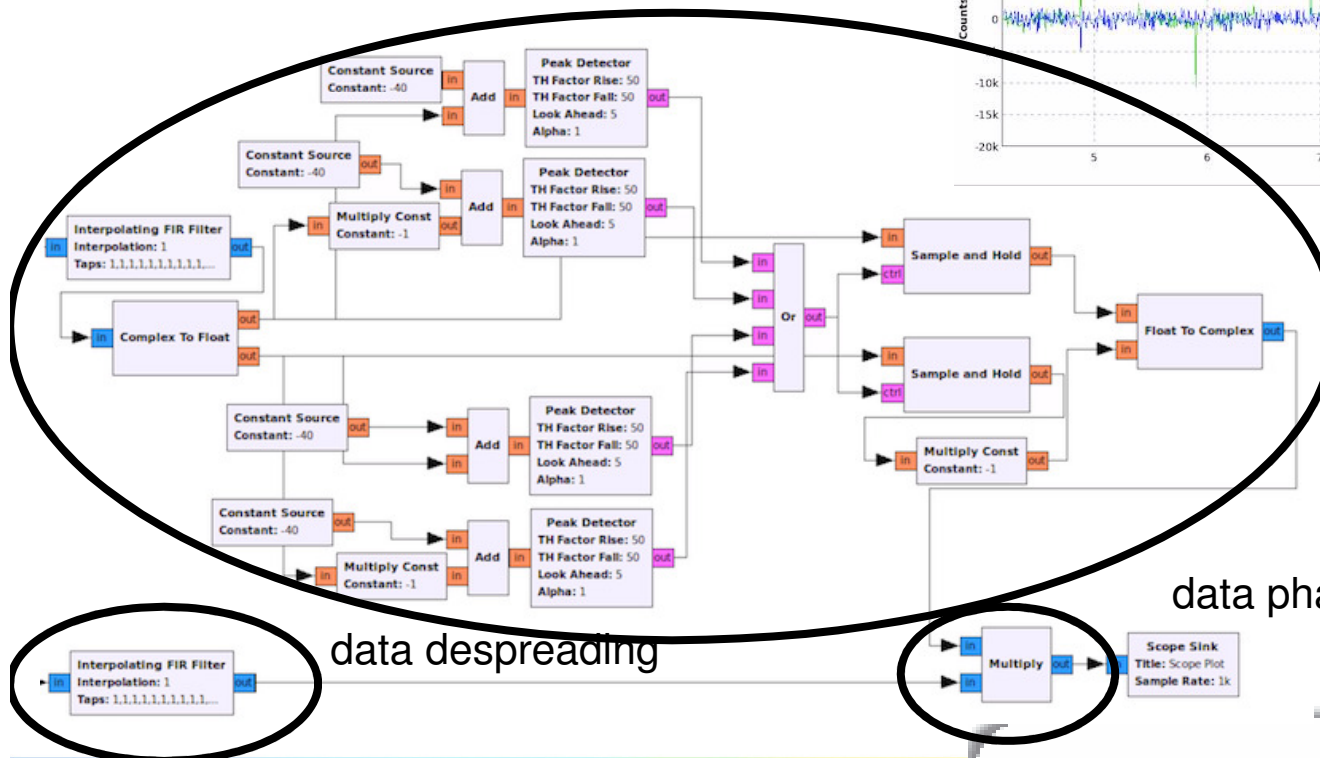

Transmitted data: sequence of $\{+1, +1, -1\}$

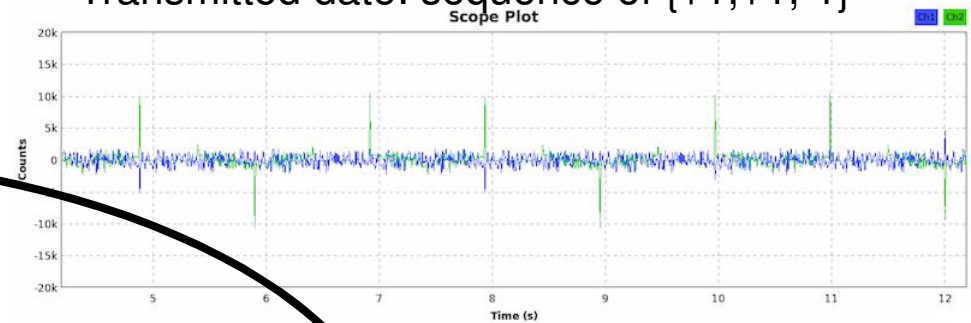

channel sounding
(just phase recovery here)

data phase correction

- **Carrier desynchronization is too high with the current system**
 - USRP1 platform
 - carrier at 2.4 GHz
 - spreading factor of 127
 - ➔ **phase is changing too much during one code sequence so that correlation is corrupted**
 - **Solutions**
 - decrease spreading factor (but loss in processing gain)
 - increase chip rate
 - decrease carrier frequency
- new platform (USRP N210)

- Past experience on channel sounding
- Student project on channel sounding
- USRP 1 experiments
- **N210 experiments**
- Conclusion

- **Development Environment**
 - SUPELEC proprietary environment (Windows)
- **UHD library**
 - from Ettus Research
- **Supporting HDCRAM**
 - **Hierarchical and Distributed Cognitive Radio Architecture Management [1]**
 - HDCRAM is an architecture for the management of reconfiguration and cognitive facilities (metrics capture and decision/learning)
 - for real-time (seemless) auto-adaptation

[1] Christophe MOY, "High-Level Design Approach for the Specification of Cognitive Radio Equipments Management APIs", Journal of Network and System Management - Special Issue on Management Functionalities for Cognitive Wireless Networks and Systems, vol. 18, number 1, pp. 64-96, Mar. 2010

- **GUI (temporary)**
 - not yet graphical capture of the radio chain
 - later: through UML graphs
- **Tx radio chain**
 - up to 1 MHz BW
 - more RF flexibility (from 100 MHz to 2 GHz in our case)

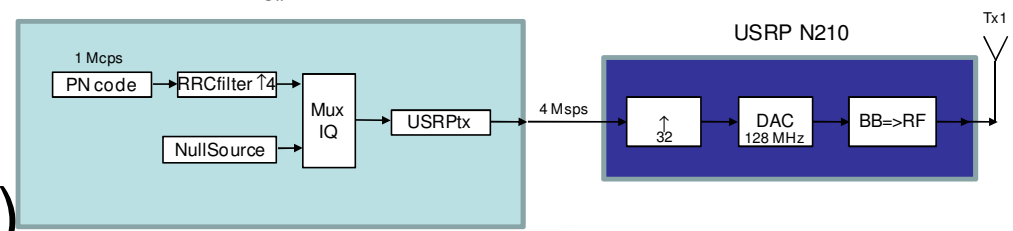
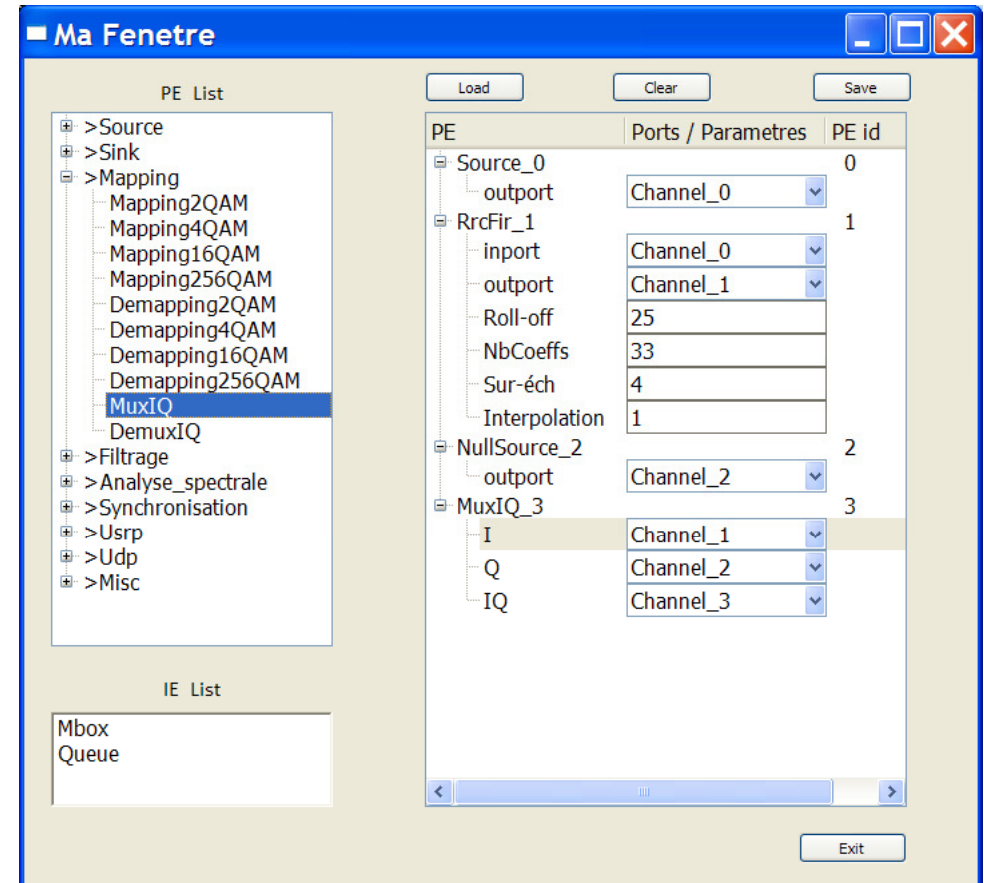

- $W = 1 \text{ MHz}$
- 1.4 GHz

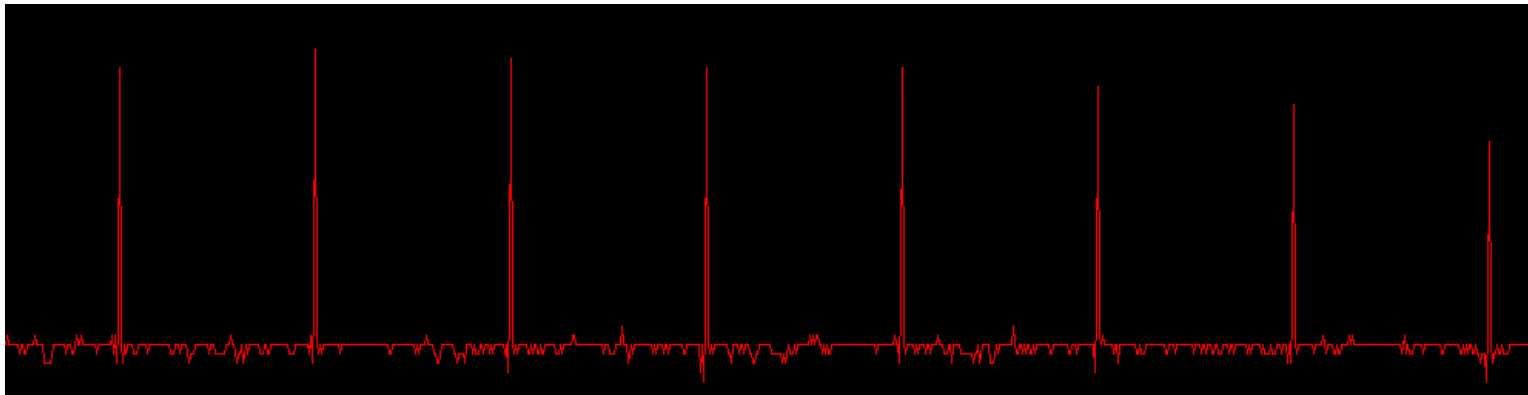

inphase signal

- no more (less visible indeed) carrier desynchronization (lucky!)
- no multipath

- Multipath environment
- Depending on capturing window zoom level



- Very easy to change of configuration (just do it!)
 - $W = 300$ kHz
 - 800 MHz
 - That was not that easy 15 years ago with the "old" approach!
- flexibility

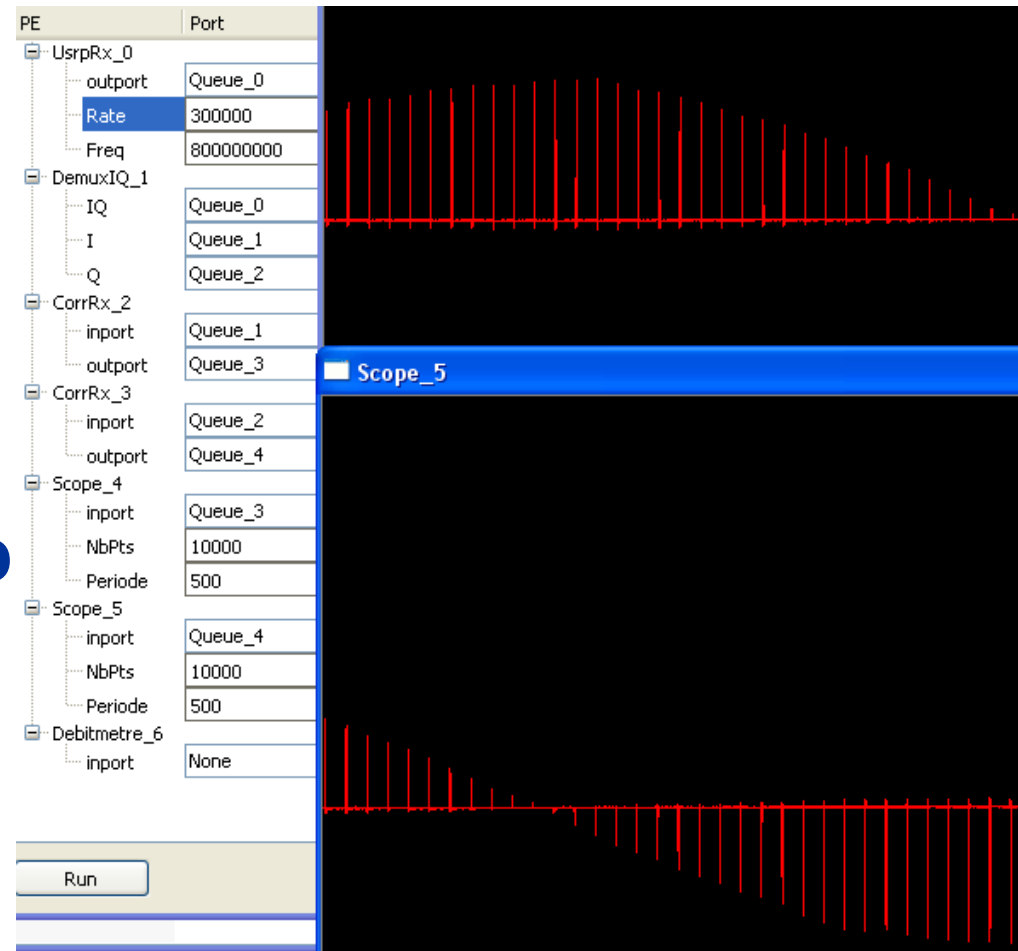

- Past experience on channel sounding
- Student project on channel sounding
- USRP 1 experiments
- N210 experiments
- **Conclusion**

- **Teaching level (project benefit for students)**
 - spread spectrum
 - digital communications in general, and more (channel sounding is not an easy thing)
 - (some) implementation limitations
 - writing a paper for a conference
- **SDR for education**
 - fast and easy to implement (even for beginner)
 - very motivating for students compared to
 - analytical analysis
 - simulations more or less disconnected from reality
 - ➔ not to replace them, but as as a complement

- **Information can be found:**

<http://www.rennes.supelec.fr/ren/perso/cmoy/SCEE-SERI/>

- **Thank you to/This is the work of students:**

Olivier GOUBET

Adrien LE NAOUR

Thanks for your attention