



***Finnish Defence
Research Agency***

Update on the Finish SDR Program

**WinnComm Europe 2018
SDR Tactical Communications Workshop**

**Principal Scientist
MSc (EE) Heikki Rantanen
Finnish Defence Research Agency**



Outline

1. Finnish Tactical C4I System M18 and new tactical radios
2. Different operating environments, different communication solutions, towards dynamic spectrum use
3. Federated Mission Networking(FMN) – our most important framework for international interoperability
4. Evolving programming methods, waveform design and implementation tools, SDR technologies and WDEs
5. HF communications – still is and remains essential for long-distance communications
6. Conclusions



Finnish Tactical C4I System M18 and new tactical radios



Finnish Tactical C4I System

—	IP-Link (BAND IV)
- - -	IP-Link (BAND III+)
- . - .	Dataradio (BAND I)
- · - ·	New SDR (BAND I)

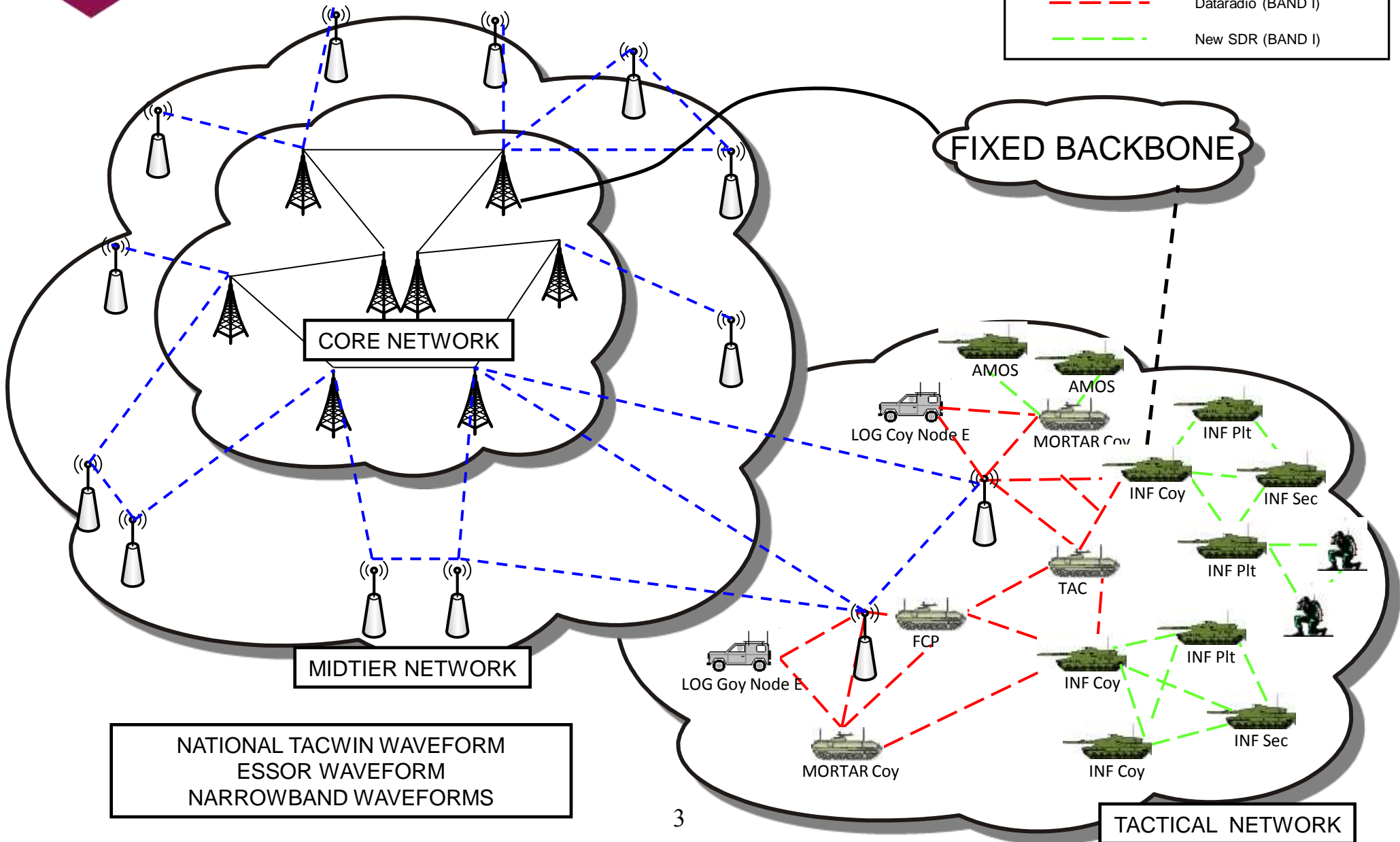



Timeline of Finnish C4I System M18

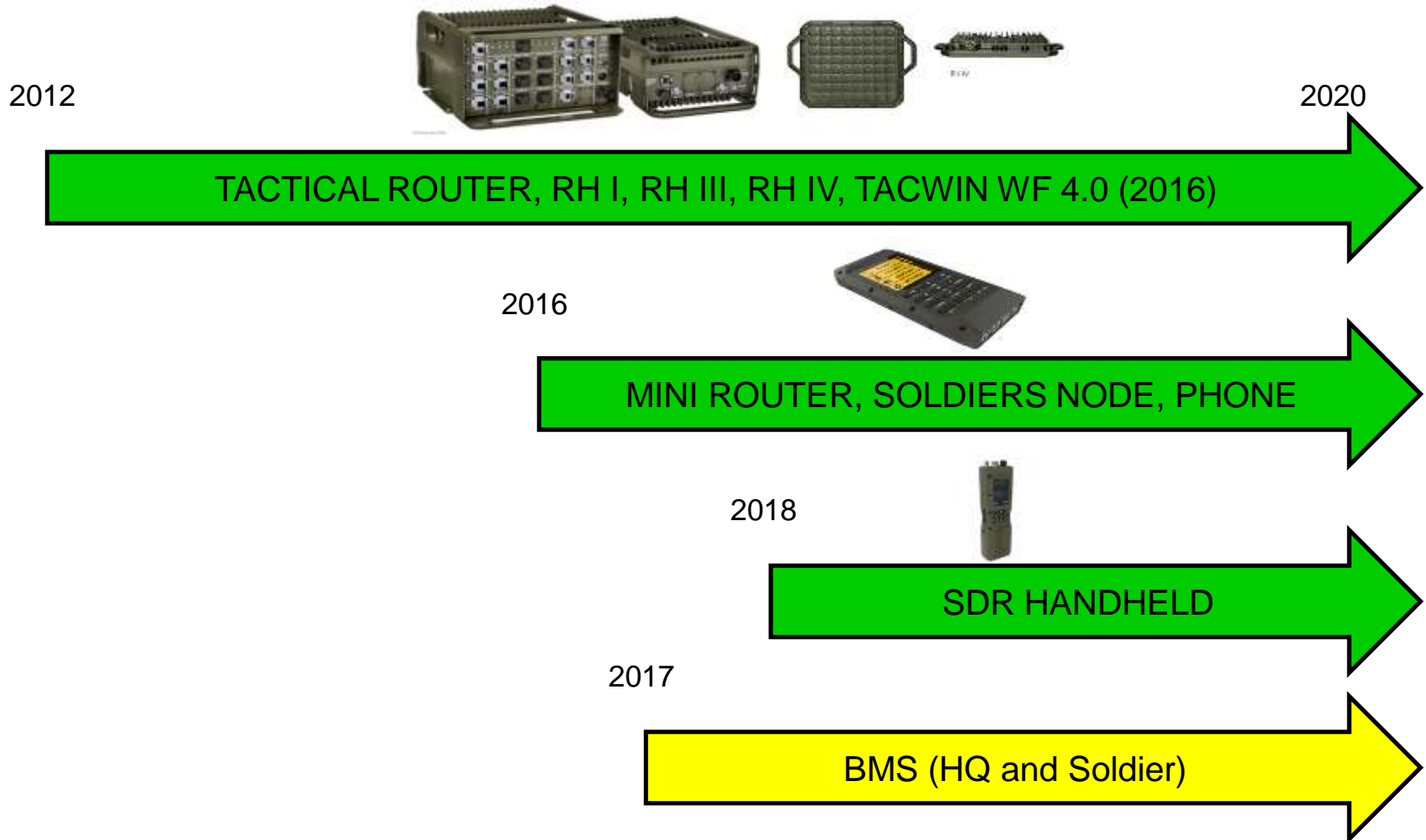



New radio from Bittium – a real platform for cognitive radio (networks)

	Tough SDR Handheld
TX (Peak Power)	30-2500MHz (5W PEP)
RX	30-2500MHz
Bandwidths	25kHz – 10MHz
Operating time (with 70Wh battery)	>12h
Size estimation	About 250x74x40mm (with 70Wh battery)
Weight estimation	About 1000g
Interfaces	<ul style="list-style-type: none">- Integrated microphone and speaker- PTT buttons- PRESET selector- DATA -connector with 100M ethernet and USB- AUDIO –connector with stereo audio- Display and navigation keys- Status leds on top of the device- WLAN / Bluetooth / GNSS





New radio from Bittium – a real platform for cognitive radio (networks)

	Tough SDR Handheld
Performance	Fast startup time Super fast waveform change times
Waveforms	TAC WIN, ESSOR and NB waveforms User can configure different waveforms to different PRESET selector positions.
Networking	Seamless networking between: <ul style="list-style-type: none">- TAC WIN IP network- ESSOR IP / Voice network- Narrowband Message / Voice network
Security	Battery backup RAM for key material, secure boot, ERASE, TAMPER protection and Red-Black separation. Possibility to develop customer specific crypto module software.
Applications	Secure application sandbox for applications <ul style="list-style-type: none">- Message application (integrated to Bittium Tough VoIP Service)- Possibility to run 3rd party applications





New radio from Bittium – a real platform for cognitive radio (networks)

	Tough SDR Vehicular
TX (Peak Power)	ANT1: 30 – 512MHz / 50W ANT2: 225 – 2500MHz / 40W
RX	ANT1: 30 – 2500MHz ANT2: 30 – 2500MHz
Bandwidths	25kHz – 10MHz
Power consumption estimate	Typ. 200W / Max. < 400W
Size estimation	About 210 x 210 x 360mm
Weight estimation	About 14 kg
Interfaces	<ul style="list-style-type: none">- PRESET selector- DATA -connector with 100M ethernet and USB- AUDIO –connector with stereo audio- Display and navigation keys- Status leds- 2x 1Gb ethernet with PoE- POWER -connector- WLAN / Bluetooth / GNSS- LTE –module option





New radio from Bittium – a real platform for cognitive radio (networks)

	Tough SDR Vehicular
Performance	Fast startup time Super fast waveform change times
Waveforms	TAC WIN, ESSOR and NB waveforms (Possibility to run two simultaneous waveform) User can configure different waveforms to different PRESET selector positions.
Networking	Seamless networking between: <ul style="list-style-type: none">- TAC WIN IP network- ESSOR IP / Voice network- Narrowband Message / Voice network
LTE option	Possibility to add separate LTE module and Bittium Safemove VPN to provide LTE connectivity.
Security	Battery backup RAM for key material, secure boot, ERASE, TAMPER protection and Red-Black separation. Possibility to develop customer specific crypto module software.
Applications	Secure application sandbox for applications <ul style="list-style-type: none">- Bittium Tough VoIP Service- Message application (integrated to Bittium Tough VoIP Service)- Possibility to run 3rd party applications





***Different operating environments,
different communication solutions,
towards dynamic spectrum use***



Different operating environments → different communication solutions

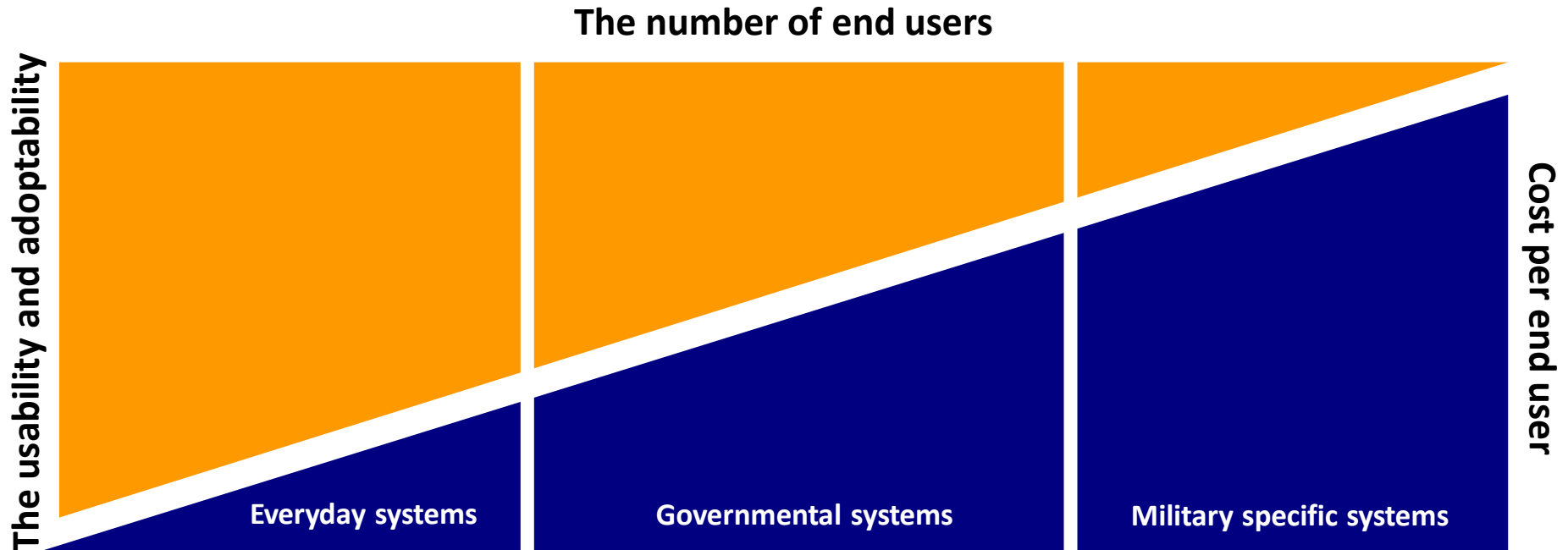

OE A

- *Mobile communication*
- *BYOD = Bring Your Own Devices*

OE B

- *Public safety communication + deployable base-stations, basestations in the air etc*
- *Mobile communication*

OE C

- *Finnish C4I System M18*
 - *Easy of use, auto-configuration*



QoS classes LTE Release 13

Standardized QoS Class Identifier (23.203 Rel 13 Mar 2016)

Policy and charging control architecture

QCI	Traffic Class	Priority	Packet delay budget	Packet error loss rate	Resource type	Example Services
1	Conversational	2	100 ms	10^{-2}	GBR	Conversational Voice
2	Conversational	4	150 ms	10^{-3}	GBR	Conversational Video (Live Streaming)
3	Streaming	3	50 ms	10^{-3}	GBR	Real Time Gaming
4	Streaming	5	300 ms	10^{-6}	GBR	Non-Conversational Video (Buffered Streaming)
65		0.7	75 ms	10^{-2}	GBR	Mission Critical user plane Push To Talk voice (e.g., MC-PTT)
66		2	100 ms	10^{-2}	GBR	Non-Mission-Critical user plane Push To Talk voice
5	Interactive	1	100 ms	10^{-6}	Non-GBR	IMS Signalling
6	Interactive	6	300 ms	10^{-6}	Non-GBR	Video (Buffered Streaming) TCP-based (e.g., www, e-mail, chat, ftp, p2p file sharing, progressive video, etc.)
7	Interactive	7	100 ms	10^{-3}	Non-GBR	Voice, Video (Live Streaming) Interactive Gaming
8	Interactive	8	300 ms	10^{-6}	Non-GBR	Video (Buffered Streaming)
9	Background	9	300 ms	10^{-6}	Non-GBR	TCP-based (e.g., www, e-mail, chat, ftp, p2p file sharing, progressive video, etc.)
69		0.5	60 ms	10^{-6}	Non-GBR	Mission Critical delay sensitive signalling (e.g., MC-PTT signalling)
70		5.5	200 ms	10^{-6}	Non-GBR	Mission Critical Data (e.g. example services are the same as QCI 6/8/9)

Source: http://niviuk.free.fr/store_lte.php



5G- welcome to OE A&B communication!

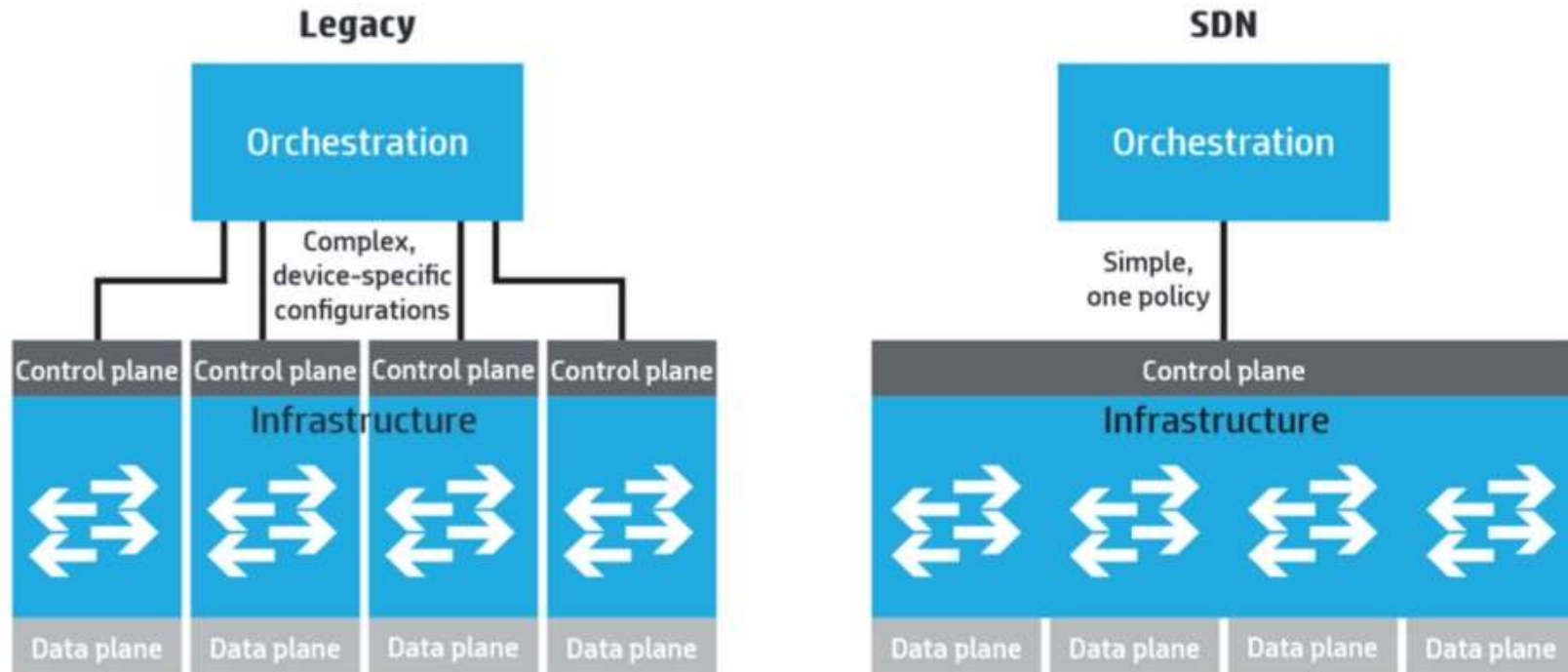

- Easier utilization of national communication infra for critical communication (CC)
 - Network Slicing – **“high priority highway for CC”**
- Advanced mobile networks
 - Higher data rates, **new tools for security, advanced priority mechanisms**, NFV
 - Massive MIMO Beamforming → **better LPI/LPD/AJ**
 - Low delay → **time critical MIL communication** (Radar data)
 - IoT communication → Sigfox, Lora type of **communication for sensors**



Public Safety Operator in future?

Dedicated public safety network

Public safety operator deploys private LTE radio access and core network infrastructure solely to provide public safety services and applications over mobile broadband.

Hybrid solution

Public safety operator has a network and/or spectrum sharing agreement with a commercial mobile network operator. The public safety operator may also implement a dedicated LTE network in key locations, while using the commercial network in other areas.

Fully commercial operator network based

Commercial mobile operator provides the full network and all services for public safety users based on a negotiated service level agreement and price.

Mobile virtual network operator (MVNO)

Public safety operator uses commercial mobile network infrastructure instead of deploying own network, but operates its own subscriber database, applications and billing services.

Source: Making mission-critical mobile broadband a reality today, NOKIA



Research topics of CORE project 2013 - 2016

- Influence of new spectrum sharing concepts on the mobile communications networks and required new testing solutions from business, regulation, and technology perspectives.
- **CORE showcased the feasibility of new frequency sharing concepts (e.g. Licensed Shared Access (LSA)) for mobile broadband networks and them to other wireless systems including public safety.**

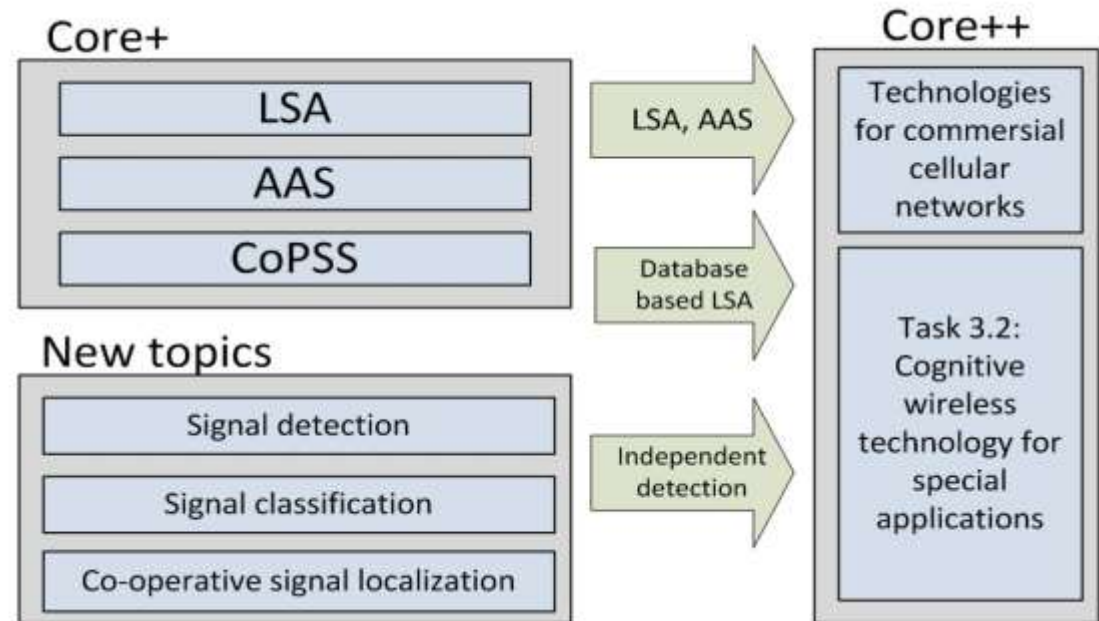



CORNET - Critical Operations over Regular Networks

Main overall research question:

“How every day’s technologies can be extended to cover special situations and applications”





CORNET Goals & Results

The main goal of the CORNET project is to develop a test environment that allows:

- Ensuring the QoS for critical communications in commercial radio networks
- Testing movable temporary radio networks for the needs of public safety and security.

Expected results include:

1. The necessary radio network functionalities for QoS control and traffic prioritization
2. Network slicing
3. Temporary radio network deployment
4. Distributed network intelligence and functionalities
5. Privacy and security of critical communications in commercial networks with everyday communication devices.



Dynamic spectrum use demo 2018

- Topi Tuukkanen, ICMCIS 2017: “Armed Forces' views on Shared Spectrum Access”
 - Main result: spectrum sharing concept should be capable of temporal changes in user roles
- This was demonstrated using real networks, real Spectrum Manager and real User Interface of the NRA to control changing priorities.

- Co-operation partners:



- Publications: Paper describing the demonstration setup submitted CrownCom 2018, paper analyzing the demonstration results submitted to IEEE DySPAN 2018

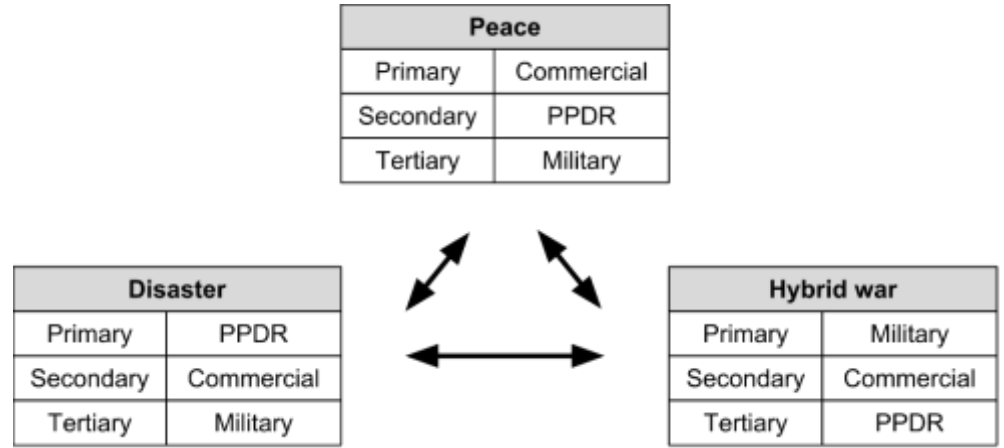

Temporal changes in user roles

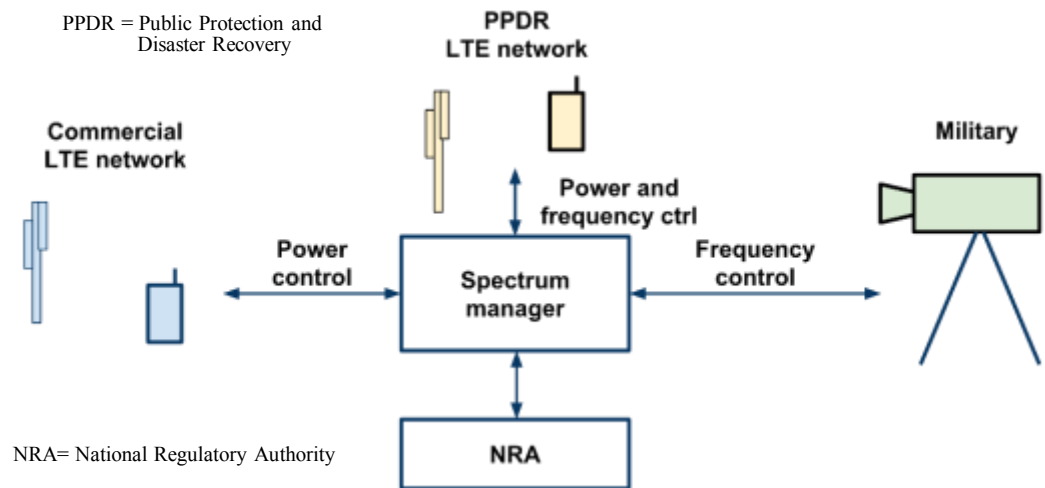

Demo 2018: Real demonstration of dynamic spectrum use



***Federated Mission Networking(FMN) –
our most important framework for
international interoperability***



Federated Mission Networking

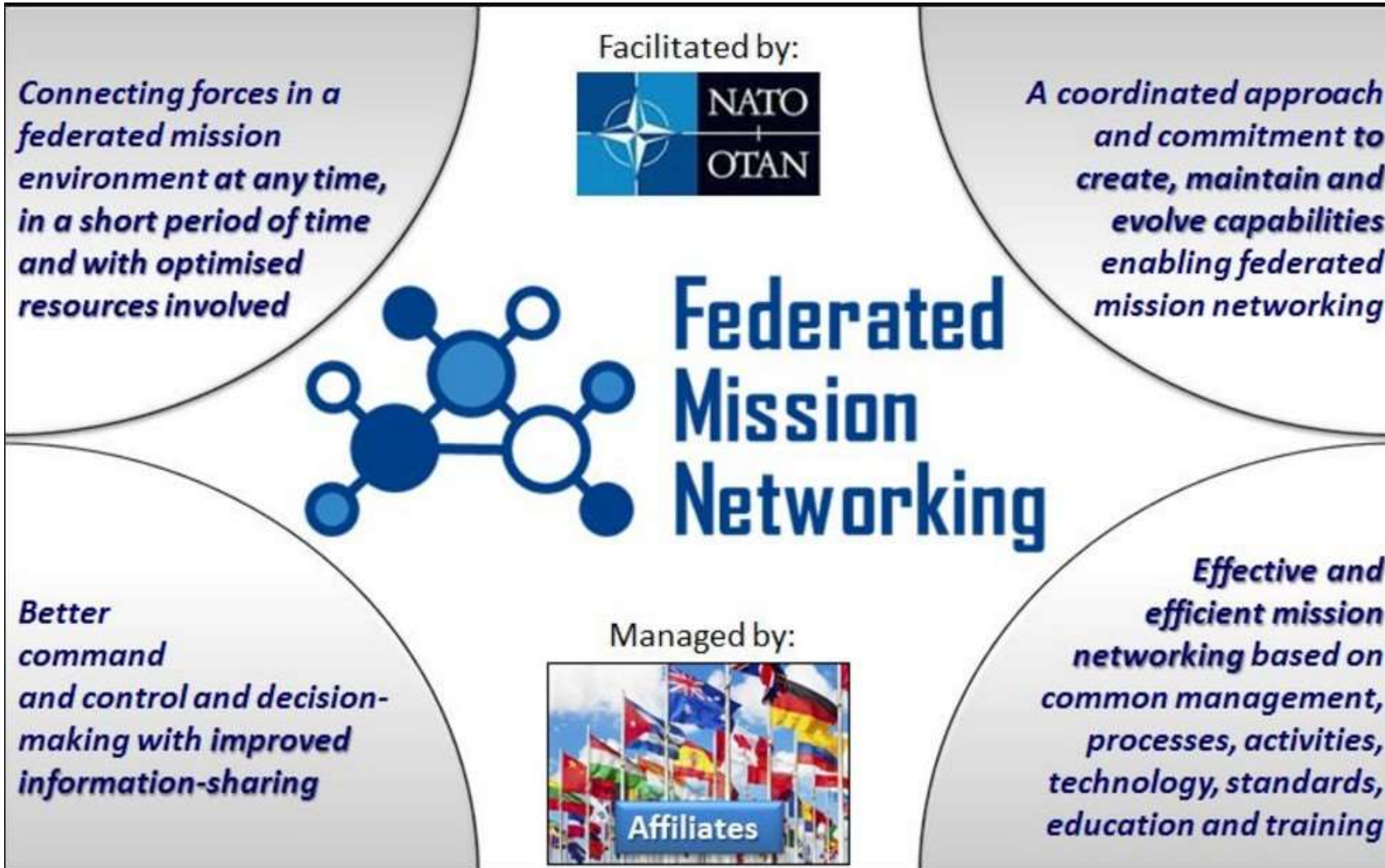

Picture: <https://dnbl.ncia.nato.int/FMN/SitePages/Home.aspx>



***Evolving programming methods,
waveform design and implementation
tools, SDR technologies and WDEs***

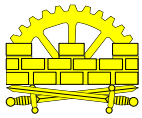

Future challenge in waveform development

- Problem of rapidly increasing complexity of WFAs and shortened time to for design and implementation
 - The code must be maintainable
 - Simulation in the early phase of the design
- ➔ Advanced system level design tools and techniques are required to solve the problem of the increasing complexity

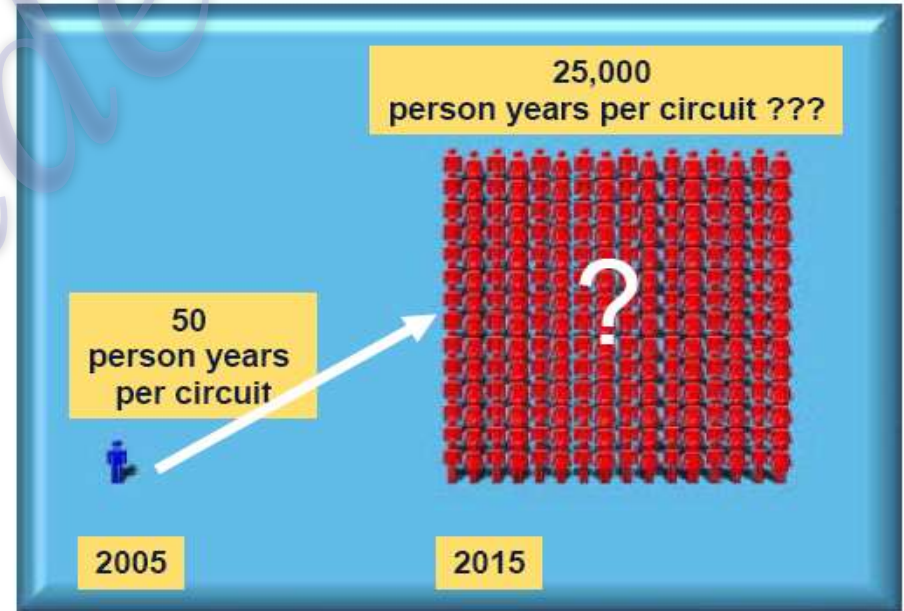

Design automation breakthroughs mandatory to win the design race!

Ref : SRA ENIAC





Trends in software design and implementation

- The constantly increasing complexity of systems force to use more and more effective software development tools with higher layer of abstractions. *MDA (Model Driven Architecture)* is one example of this paradigm.

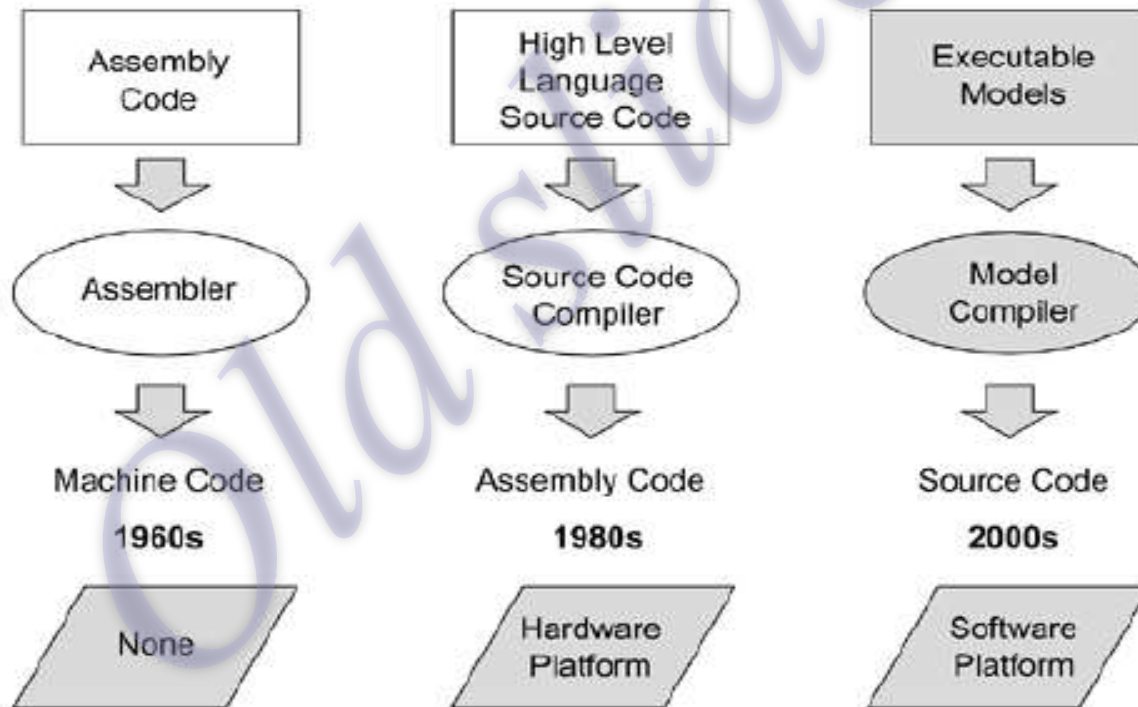

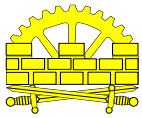

Portability of source code

(Source: L3-Nova white paper “TECHNIQUES AND RECOMMENDATIONS TO IMPROVE WAVEFORM PORTABILITY”)

- Often the primary (sometimes the only) artifact delivered to a waveform porting team is source code. **Source code, no matter how thoughtfully designed, is not sufficient to realize a truly portable waveform or to port waveform software efficiently.** Source code has often been optimized for a particular platform or device, can be hard to read and does not provide enough information for effective debugging. **In fact, source code alone is of limited importance, and should be only one component of a waveform’s Portability Toolkit**
- **Portability toolkit**
 1. *Detailed system, software and design documentation*
 2. *A non-real time, PC-based emulator*
 3. *Full, functional and bit-true waveform behavioral models and simulations in MATLAB, Simulink and/or OPNET*
 4. *Testbenches and test vectors at both the component level and top level*
 5. *Source code*





Portability of source code

(Source: L3-Nova white paper “TECHNIQUES AND RECOMMENDATIONS TO IMPROVE WAVEFORM PORTABILITY”)

- **In case of C++**, detailed class diagrams, intended multi-threading scheme and comprehensive **unified modeling language (UML)** sequence diagrams would go a long way in painting the overall picture that is generally missing when just looking at source code.
- **In case of the VHDL**, diagrams of the clocking scheme, detailed block diagrams and RTL documentation for each of the primary components would be especially helpful.

COMMENT 23.05.2018

- **ESSOR represents a totally new performance and capability as a tactical waveform.**
- **ESSOR WF design methodology covers all elements of “Portability Toolkit”.**
- **Only over-the-air interoperability matters from waveform user point of view → European SDR Waveform Certification Capability is needed → Golden Reference Implementation → Also test capability of large military networks is needed.**





HLS & OpenCL – new FPGA programming tools

- **High-Level Synthesis (HLS) tools** translate the functions meant to be accelerated in synthesizable code in the FPGA.
 - Algorithm is designed in C/C++/ System C and it is debugged within the same development environment
 - Afterwards, the algorithm is synthesized by generating the hardware code (RTL) using HLS tool.
- **OpenCL (Open Computing Language) is a framework for writing programs that execute across heterogeneous platforms consisting of CPUs, GPUs, DSPs and FPGAs.**
 - OpenCL enables developers to implement their algorithms in C-like source code, and execute without modification in a variety of processor types, making it easier to develop applications and improve performance by selecting the appropriate processor type.





Evolving SDR technology (1)

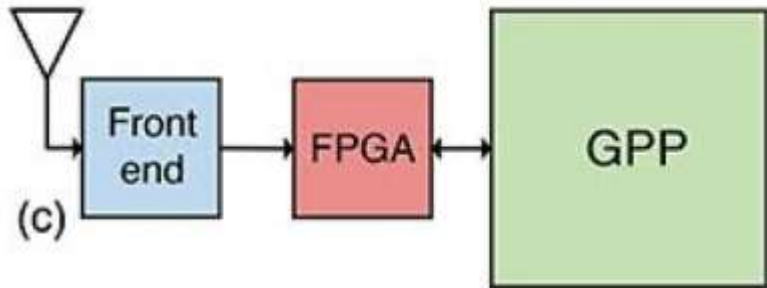
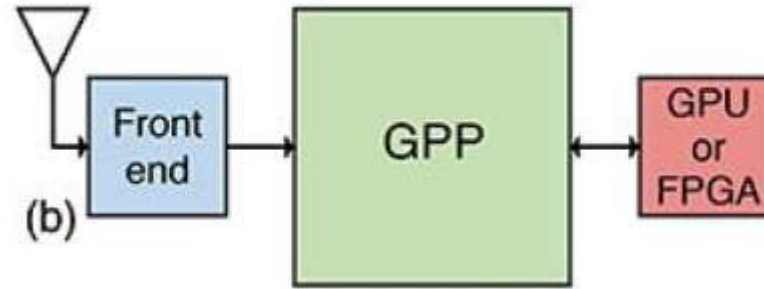
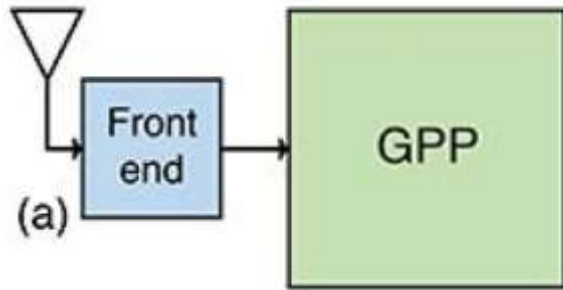

- *First generation SDR implementation technology at the time when SCA was specified*
- *Separate GPP, FPGA, GPU and DSP components*
- *C++ and VHDL were predominant programming languages in embedded devices like radio*
- *It was natural to choose source code portability as a methodology to enhance more effective programming i.e. program code portability and software component reuse.*

Pictures: <http://gpsworld.com/innovation-the-continued-evolution-of-the-gnss-software-defined-radio/>

Evolving SDR technology (2)

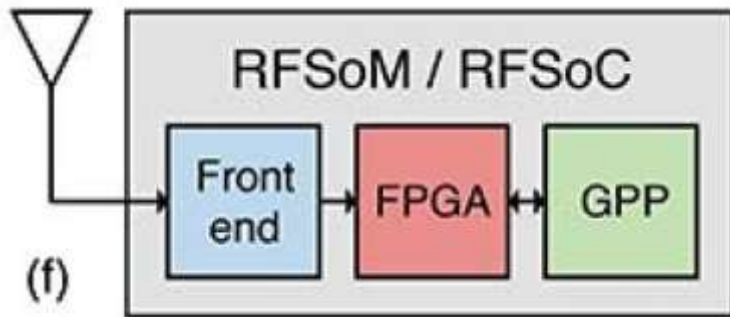
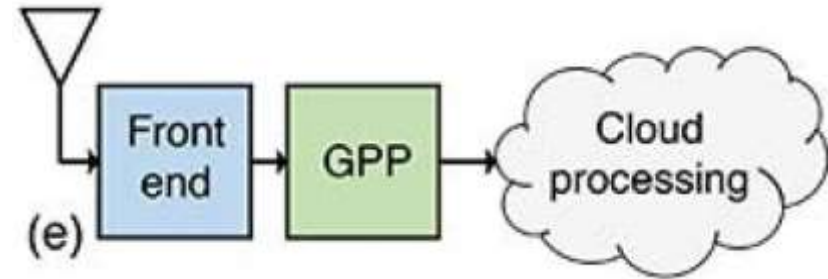
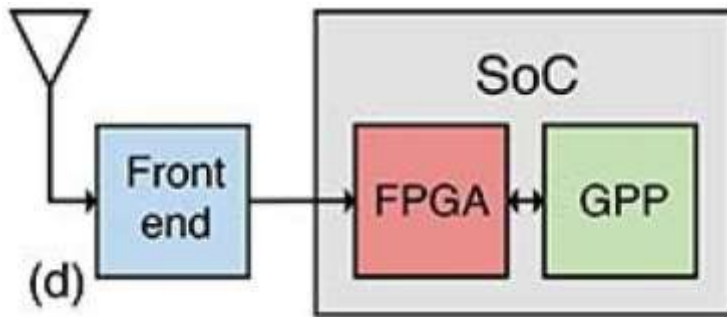

RFSOM = radio-frequency system on module
RFSOC = radio-frequency system on chip

- **Situation today and in future. SoC integrates FPGA, GPP and even RF Front End on same chip/module**
 - **Cloud computing**
 - **It is impossible to integrate all parts of SCA on the chip. SoC manufacturer offers efficient higher level modelling tools (like HLS and OpenCL) to implement signal processing algorithms**
- ➔ **Enables move from “source code portability to WF design flow portability”**

Pictures: <http://gpsworld.com/innovation-the-continued-evolution-of-the-gnss-software-defined-radio/>



New approach to WDE (Waveform Development Environment)

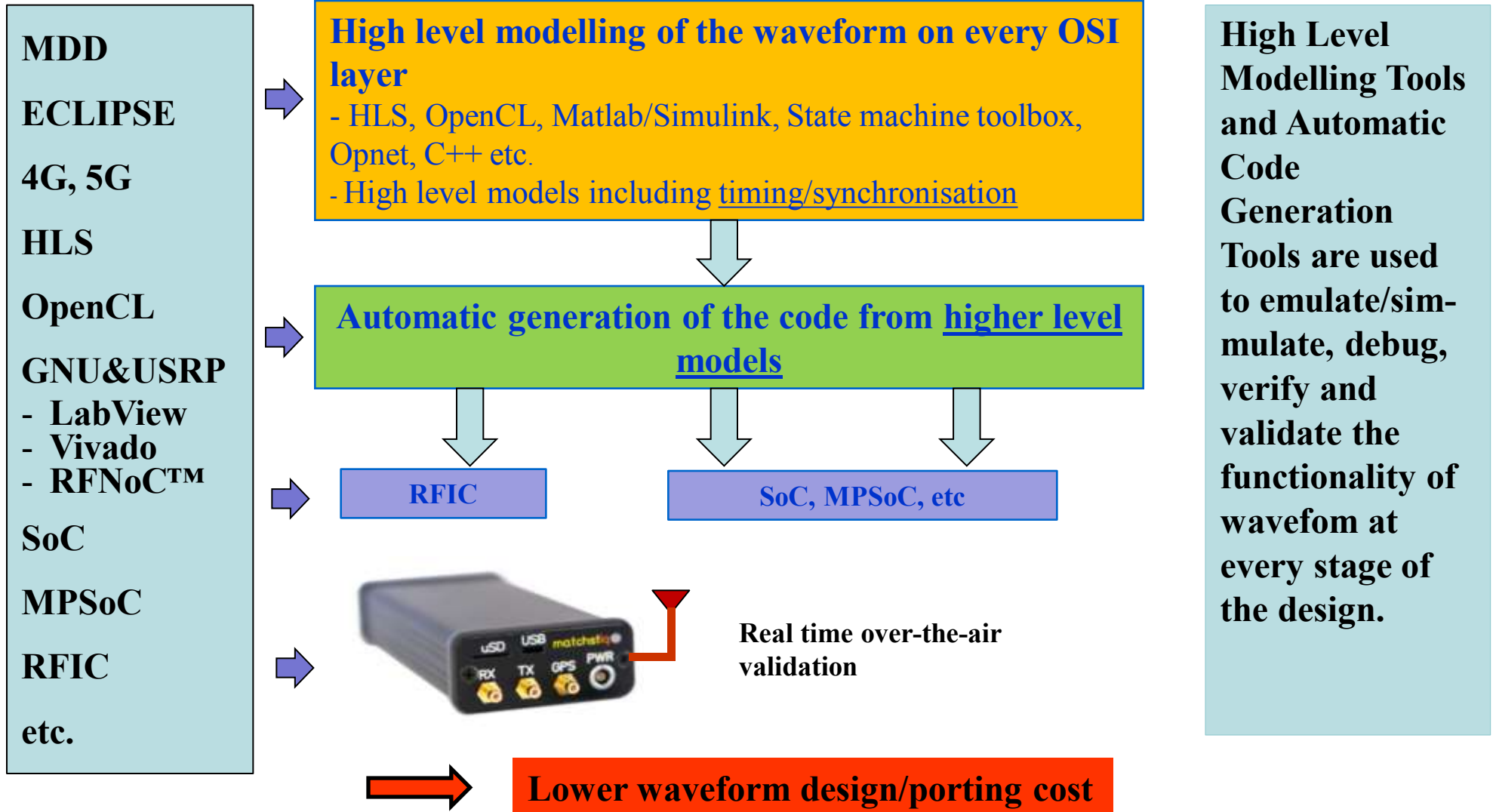



HF communications – still is and remains essential for long-distance communications



Characteristics of HF communications

- Only HF-radio can offer communication range 0 km ... 1160 km (Vertical length of Finland)
 - Satellite communication capability at Arctic latitudes can be limited
- State of the art WBHF radio can deliver rates up to 200..300 kbps in a 48 kHz wide channel.
 - Modern HF-radio can be a real alternative to narrow-band SATCOM
- It is obvious that even better data rate is achievable → Future WBHF
- An HF-network can be fully IP-compatible and act as a backup network for a fixed IP-network
 - For example large-scale cyber attack



FDF HF-activities during recent years

- HF-propagation measurement campaign 2015 – 2016 on Finnish region
 - Surface wave, NVIS and ionospheric propagation
 - 24//7/365 measurement using KNL radio(almost real-time spectrum sensing, adaptive modulation and bandwidth)
 - Also sporadic propagation phenomena were observed
 - Test messages
 - Measured parameters were data rate, modulation and bandwidth
- valuable information of Finnish HF-propagation environment and first findings what kind of new capability modern SDR HF-radio can offer



FDF HF-activities during recent years

- Broadband HF-channel measurements in Finland (2015)
 - One of the research topics: Existence of single path channels in case of ground wave and NVIS
 - KNL Networks, TUT, UoO(CWC)
- FDR Research program 2013 (3 years programme) included also HF communication research topics
 - New physical layer modulation schemes
 - Main emphasis on different kind of multi-carrier modulation schemes
 - Tampere University of Technology and KNL Networks
 - HF IP-networking
 - Tampere University of Technology and Finnish Research Agency(VTT)



FDF HF-activities during recent years

- One week intensive course on HF communications focusing on physical layer issues in the beginning of this year (given by RF-Shamans Ltd)
 - Participants from all defence branches: HF-operators, officers, engineers...challenging audience...but successful course !!
 - Main themes: HF-propagation modes, antennas, disturbances, ALE, Ionospheric Sounding, EW and HF, etc
 - Some interesting observations:
 - Disturbances (man made) are the most limiting factor in HF communications – find and eliminate them as far as possible !
 - Wanted propagation mode → right antenna and frequency --> adaptive modulation and bandwidth are basic conditions for successful HF communications
 - Ionospheric propagation is different in the Arctic and Central Europe (elliptically polarized circular refracted component)
 - etc



Cognitive SDR HF radio from KNL networks

Cognitive Spectrum Management

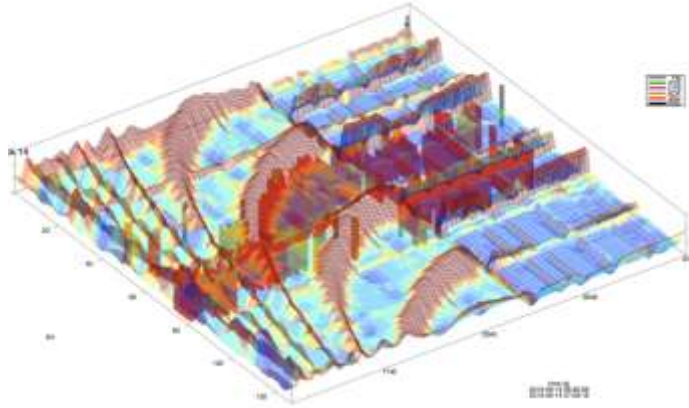

- Purpose-built wideband SDR HF radio with emphasis on cognitive features
- Receives the whole HF band simultaneously
- Bandwidths 1.8 - 24 (48, 96) kHz (Modulations: BPSK - 256QAM, data rates up to 153 kbit/s)
- Wide Band ALE with thousands of simultaneously listened calling channels
- Cognitive spectrum usage
- Built-in PA w/ max 250 W PEP
- Built-in GNSS, 2xEthernet, 3G Cellular modem, WIFI
- Networked HF radio with several networking modes
- In commercial use with maritime industry
- Pilot tests in FDRA, tests ongoing in the Finnish Border Guard, operational use in The Finnish Navy
- Made in Finland
- More info: <https://knlnetworks.com/>



Need for Future WBHF standard

- In the past, and at present, several national research projects aim for better performance in HF communication.
 - Studied topics typically are:
 1. Better physical layer data rate
 2. Mac layer solution to overcome high delay and data rate variations
 3. Full IP-networking support
- There is no ALE-standard supporting WBHF radio with almost real-time spectrum sensing capacity.
- There is a operational need for HF-radio with the performance described earlier in this presentation
- The work that aims to develop Future WBHF standard should utilise the work done in different countries. Furthermore, the work should taken place in Intercontinental/European cooperation in order to be widely accepted among SDR manufacturers and nations as a (de facto) standard.



European forum for Future WBHF standardization?

- EU has launched a series of new initiatives to boost European defence cooperation:
 - Coordinated Annual Review on Defence (CARD)
 - Permanent Structured Cooperation (PESCO)
 - European Defence Fund (EDF)
 - EDF's research window (Preparatory Action now, EDRP in the future)
- "Long range communication" was high on the list (also In Finland) as EDA nations voted for critical TBBs (Technical Building Blocks) in OSRA (Overarching Strategic Research Agenda) work.
- Finland is more than ready for discussions, with other nations, to set up a project for creating a Future WBHF standard and is ready to contribute to this work with our national know-how described in this presentation.
- Waveform design and implementation should be done using state of the art WDE.



Conclusions

FDF is equipping troops with SDR radios and waveforms. This results in better communication capability and better international interoperability (the role of FMN is essential). Our new SDR is an ideal platform for cognitive radio.

Different operating environments (A, B, C) of FDF lead to different communication solutions. The seamless communication across OEs is essential.

SDR technology and WDE tools are constantly developing. This will bring more efficiency to SDR waveform development.

HF-communication is essential and important part of military communication. Development of Future WBHF would be an excellent cooperative effort for example in Europe.



Thank you !

For more information contact:

Petteri Kuosmanen, Defence Command J6
FIN SDR Program
petteri.kuosmanen@mil.fi

Topi Tuukkanen, FDRA
Cognitive radios and Networks
topi.tuukkanen@mil.fi

Heikki Rantanen, FDRA
SDR and waveforms
heikki.rantanen@mil.fi